

# User Manual

## PV Grid-Connected Inverter

SG285HX / SG320HX / SG333HX / SG350HX







# All Rights Reserved

## **All Rights Reserved**

No part of this document can be reproduced in any form or by any means without the prior written permission of Sungrow Power Supply Co., Ltd (hereinafter "SUNGROW").

## **Trademarks**

**SUNGROW** and other Sungrow trademarks used in this manual are owned by SUNGROW.

All other trademarks or registered trademarks mentioned in this manual are owned by their respective owners.

## **Software Licenses**

- It is prohibited to use data contained in firmware or software developed by SUNGROW, in part or in full, for commercial purposes by any means.
- It is prohibited to perform reverse engineering, cracking, or any other operations that compromise the original program design of the software developed by SUNGROW.

# About This Manual

The manual mainly contains the product information, as well as guidelines for installation, operation, and maintenance. The manual does not include complete information about the photovoltaic (PV) system. Readers can get additional information at [www.sungrowpower.com](http://www.sungrowpower.com) or on the webpage of the respective component manufacturer.

## Validity

This manual is valid for the following model of low-power grid-connected PV string inverters:

- SG285HX
- SG320HX
- SG333HX
- SG350HX

It will be referred to as "inverter" hereinafter unless otherwise specified.

## Target Group

This manual is intended for professional technicians who are responsible for installation, operation, and maintenance of inverters, and users who need to check inverter parameters.

The inverter must only be installed by professional technicians. The professional technician is required to meet the following requirements:

- Know electronic, electrical wiring and mechanical expertise, and be familiar with electrical and mechanical schematics.
- Have received professional training related to the installation and commissioning of electrical equipment.
- Be able to quickly respond to hazards or emergencies that occur during installation and commissioning.
- Be familiar with local standards and relevant safety regulations of electrical systems.
- Read this manual thoroughly and understand the safety instructions related to operations.

## How to Use This Manual

Please read this manual carefully before using the product and keep it properly at a place for easy access.

All contents, pictures, marks, and symbols in this manual are owned by SUNGROW. No part of this document may be reprinted by the non-internal staff of SUNGROW without written authorization.

Contents of this manual may be periodically updated or revised, and the actual product purchased shall prevail. Users can obtain the latest manual from [support.sungrowpower.com](http://support.sungrowpower.com) or sales channels.

## Symbols

This manual contains important safety instructions, which are highlighted with the following symbols, to ensure personal and property safety during usage, or to help optimize the product performance in an efficient way.

Please carefully understand the meaning of these warning symbols to better use the manual.

### DANGER

Indicates high-risk potential hazards that, if not avoided, may lead to death or serious injury.

### WARNING

Indicates moderate-risk potential hazards that, if not avoided, may lead to death or serious injury.

### CAUTION

Indicates low-risk potential hazards that, if not avoided, may lead to minor or moderate injury.

### NOTICE

Indicates potential risks that, if not avoided, may lead to device malfunctions or financial losses.



“NOTE” indicates additional information, emphasized contents or tips that may be helpful, e.g., to help you solve problems or save time.



# Contents

---

All Rights Reserved .....	I
About This Manual .....	II
<b>1 Safety Instructions .....</b>	<b>1</b>
1.1 Unpacking and Inspection .....	2
1.2 Installation Safety .....	2
1.3 Electrical Connection Safety .....	3
1.4 Operation Safety .....	4
1.5 Maintenance Safety .....	5
1.6 Disposal Safety .....	6
<b>2 Product Description .....</b>	<b>7</b>
2.1 System Introduction .....	7
2.2 Product Introduction .....	8
2.3 Symbols on Product .....	9
2.4 LED Indicator .....	10
2.5 DC Switch .....	11
2.6 Circuit Diagram .....	11
2.7 Function Description .....	12
<b>3 Unpacking and Storage .....</b>	<b>15</b>
3.1 Unpacking and Inspection .....	15
3.2 Unpacking Steps .....	15
3.3 Inverter Storage .....	17
<b>4 Mechanical Mounting .....</b>	<b>18</b>
4.1 Safety During Mounting .....	18
4.2 Location Requirements .....	19
4.2.1 Environment Requirements .....	19
4.2.2 Carrier Requirements .....	20
4.2.3 Angle Requirements .....	20
4.2.4 Clearance Requirements .....	21
4.3 Installation Tools .....	23
4.4 Moving Inverter .....	24
4.4.1 Manual Transport .....	24

4.4.2 Hoisting Transport.....	25
4.5 Installing Mounting-bracket.....	27
4.5.1 Bracket-Mounted Installation.....	28
4.5.2 Wall-Mounted Installation.....	30
4.5.3 Pole-Mounting .....	32
4.6 Installing the Inverter.....	35
<b>5 Electrical Connection .....</b>	<b>36</b>
5.1 Safety Instructions.....	36
5.2 Terminal Description .....	38
5.3 Electrical Connection Overview .....	40
5.4 Crimp OT/DT terminal.....	43
5.5 External Protective Grounding Connection .....	44
5.5.1 External Protective Grounding Requirements.....	44
5.5.2 Connection Procedure.....	45
5.6 AC Cable Connection .....	45
5.6.1 AC Side Requirements .....	45
5.6.2 Requirements for OT/DT Terminal .....	48
5.6.3 Connection Procedure of One Wire per Phase with Multi-core Cable .....	49
5.6.4 Connection Procedure of Two Wires per Phase with Multi-core Cable .....	54
5.7 DC Cable Connection .....	58
5.7.1 PV Input Configuration .....	59
5.7.2 Assembling PV Connectors .....	60
5.7.3 Installing PV Connector .....	62
5.8 Wiring of Tracking System Power Cable (Optional) .....	63
5.9 RS485 Connection(COM1).....	65
5.9.1 Interface Description .....	65
5.9.2 RS485 Communication System.....	66
5.9.3 Connection Procedure.....	67
5.10 Dry Contact Connection(COM2) .....	70
5.10.1 Interface Description .....	70
5.10.2 Dry Contact Function.....	71
5.10.3 Connection Procedure.....	72
5.11 PLC Communication Connection .....	75
<b>6 Commissioning .....</b>	<b>78</b>

6.1 Inspection Before Commissioning .....	78
6.2 Commissioning Procedure .....	78
<b>7 iSolarCloud App .....</b>	<b>80</b>
7.1 Brief Introduction .....	80
7.2 Installing App .....	80
7.3 Login .....	81
7.3.1 Requirements .....	81
7.3.2 Login Procedure .....	81
7.4 Function Overview .....	84
7.5 Home .....	84
7.6 Run Information .....	86
7.7 Records .....	88
7.8 More .....	90
7.8.1 System Parameters .....	90
7.8.2 Operation Parameters .....	91
7.8.3 Power Regulation Parameters .....	92
7.8.4 Communication Parameters .....	97
7.8.5 Firmware Update .....	98
7.8.6 Password Changing .....	99
<b>8 Troubleshooting and Maintenance .....</b>	<b>100</b>
8.1 Troubleshooting .....	100
8.2 Maintenance .....	108
8.2.1 Maintenance Notices .....	108
8.2.2 Disconnecting Inverter .....	109
8.2.3 Routine Maintenance .....	110
8.2.4 Cleaning Air Inlet and Outlet .....	110
8.2.5 Fan Maintenance .....	111
8.3 Inverter Disposal .....	113
8.3.1 Dismantling the Inverter .....	113
8.3.2 Disposal of Inverter .....	114
<b>9 Appendix .....</b>	<b>115</b>
9.1 Technical Data .....	115
9.2 Wring Distance of DI Dry Contact .....	119
9.3 Quality Assurance .....	120
9.4 Contact Information .....	121





# 1 Safety Instructions

When installing, commissioning, operating, and maintaining the product, strictly observe the labels on the product and the safety requirements in the manual. Incorrect operation or work may cause:

- Injury or death to the operator or a third party.
- Damage to the product and other properties.

## WARNING

- **Do not operate the product and cables (including but not limited to moving the product, installing the product, operating the product and cables, powering up the product, maintaining the product, and working at heights) in harsh weather conditions such as lightning, rain, snow, and level 6 or stronger wind.**
- **In case of fire, evacuate from the building or product area and call the fire alarm. Re-entry into the burning area is strictly prohibited under any circumstances.**

## NOTICE

- **Tighten the screws with the specified torque using tools when fastening the product and terminals. Otherwise, the product may be damaged. And the damage caused is not covered by the warranty.**
- **Learn how to use tools correctly before using them to avoid hurting people or damaging the device.**
- **Maintain the device with sufficient knowledge of this manual and use proper tools.**



- The safety instructions in this manual are only supplements and cannot cover all the precautions that should be followed. Perform operations considering actual onsite conditions.
- SUNGROW shall not be held liable for any damage caused by violation of general safety operation requirements, general safety standards, or any safety instruction in this manual.
- When installing, operating, and maintaining the product, comply with local laws and regulations. The safety precautions in this manual are only supplements to local laws and regulations.

## 1.1 Unpacking and Inspection

### WARNING

- Check all safety signs, warning labels and nameplates on devices.
- The safety signs, warning labels and nameplates must be clearly visible and cannot be removed or covered before the device is decommissioned.

### NOTICE

After receiving the product, check whether the appearance and structural parts of the device are damaged, and check whether the packing list is consistent with the actual ordered product. If there are problems with the above inspection items, do not install the device and contact your distributor first. If the problem persists, contact SUNGROW in time.

## 1.2 Installation Safety

### DANGER

- Make sure there is no electrical connection before installation.
- Before drilling, avoid the water and electricity wiring in the wall.

### CAUTION

Improper installation may cause personal injury!

- If the product supports hoisting transport and is hoisted by hoisting tools, no one is allowed to stay under the product.
- When moving the product, be aware of the product weight and keep the balance to prevent it from tilting or falling.

### NOTICE

Before operating the product, must check and ensure that tools to be used have been maintained regularly.

## 1.3 Electrical Connection Safety

### DANGER

- Before electrical connections, please make sure that the inverter is not damaged, otherwise it may cause danger!
- Before electrical connections, please make sure that the inverter switch and all switches connected to the inverter are set to "OFF", otherwise electric shock may occur!

### DANGER

The PV string will generate lethal high voltage when exposed to sunlight.

- Operators must wear proper personal protective equipment during electrical connections.
- Must ensure that cables are voltage-free with a measuring instrument before touching DC cables.
- Respect all safety instructions listed in relevant documents about PV strings.
- The inverter must not be connected to a PV string that requires positive or negative grounding.

### DANGER

**Danger to life due to a high voltage inside the inverter!**

- Be sure to use special insulation tools during cable connections.
- Note and observe the warning labels on the product, and perform operations strictly following the safety instructions.
- Respect all safety instructions listed in this manual and other pertinent documents.

### WARNING

Damage to the product caused by incorrect wiring is not covered by the warranty.

- Electrical connection must be performed by professionals.
- All cables used in the PV generation system must be firmly attached, properly insulated, and adequately dimensioned.

**⚠ WARNING**

- Check the positive and negative polarity of the PV strings, and connect the PV connectors to corresponding terminals only after ensuring polarity correctness.
- During the installation and operation of the inverter, please ensure that the positive or negative poles of PV strings do not short-circuit to the ground. Otherwise, an AC or DC short-circuit may occur, resulting in equipment damage. The damage caused by this is not covered by the warranty.

**NOTICE**

Comply with the safety instructions related to PV strings and the regulations related to the local grid.

## 1.4 Operation Safety

**⚠ DANGER**

When routing cables, ensure a distance of at least 30 mm between the cables and heat-generating components or areas to protect the insulation layer of cables from aging and damage.

**⚠ DANGER**

When the product is working:

- Do not touch the product enclosure.
- It is strictly forbidden to plug and unplug any connector on the inverter.
- Do not touch any wiring terminal of the inverter. Otherwise, electric shock may occur.
- Do not disassemble any parts of the inverter. Otherwise, electric shock may occur.
- It is strictly forbidden to touch any hot parts of the inverter (such as the heat sink). Otherwise, it may cause burns.
- Do not connect or remove any PV string or any PV module in a string. Otherwise, electric shock may occur.

## 1.5 Maintenance Safety

### DANGER

**Risk of inverter damage or personal injury due to incorrect service!**

- Before maintenance, disconnect the AC circuit breaker on the grid side and then the DC switch. If a fault that may cause personal injury or device damage is found before maintenance, disconnect the AC circuit breaker and wait until the night before operating the DC switch. Otherwise, a fire inside the product or an explosion may occur, causing personal injuries.
- After the inverter is powered off for 25 minutes, measure the voltage and current with professional instrument. Only when there is no voltage nor current can operators who wear protective equipment operate and maintain the inverter.
- Even if the inverter is shut down, it may still be hot and cause burns. Wear protective gloves before operating the inverter after it cools down.

### DANGER

**Touching the power grid or the contact points and terminals on the inverter connected to the power grid may lead to electric shock!**

- The power grid side may generate voltage. Always use a standard voltmeter to ensure that there is no voltage before touching.

### CAUTION

**To prevent misuse or accidents caused by unrelated personnel, post prominent warning signs or demarcate safety warning areas around the product.**

### NOTICE

**To avoid the risk of electric shock, do not perform any other maintenance operations beyond this manual. If necessary, contact SUNGROW for maintenance. Otherwise, the losses caused is not covered by the warranty.**

### NOTICE

- If the paint on the inverter enclosure falls or rusts, repair it in time. Otherwise, the inverter performance may be affected.
- Do not use cleaning agents to clean the inverter. Otherwise, the inverter may be damaged, and the loss caused is not covered by the warranty.
- As the inverter contains no parts that can be maintained, never open the enclosure of the inverter or replace any internal components without authorization. Otherwise, the loss caused is not covered by the warranty.

## 1.6 Disposal Safety

 **WARNING**

**Please scrap the product in accordance with relevant local regulations and standards to avoid property losses or casualties.**

## 2 Product Description

### 2.1 System Introduction

The inverter is a transformerless 3-phase PV grid-connected inverter. As an integral component in the PV power system, the inverter is designed to convert the direct current power generated from the PV modules into grid-compatible AC current and to feed the AC current into the utility grid.

#### **⚠ WARNING**

**Do not connect any local load between the inverter and the AC circuit breaker except for the tracking axis.**

#### **NOTICE**

**When designing the system, ensure that the operating ranges of all devices that are connected to the inverter meet the requirements of the inverter.**

**The PV modules in the system must comply with the IEC 61730-1 (2016) class II standard.**

**The inverter is only applicable to the scenarios described in the manual and cannot be used in other situations.**

The intended usage of the inverter is illustrated in the following figure.

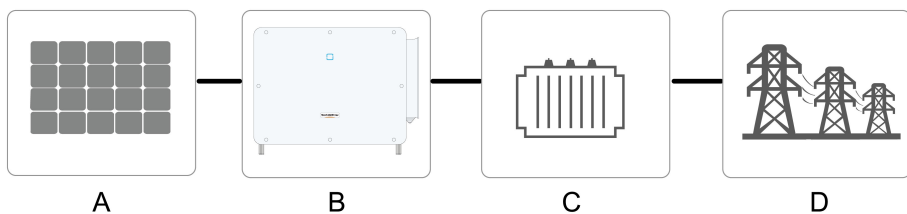

**figure 2-1** Inverter Application in PV Power System

Item	Description	Note
A	PV strings	Monocrystalline silicon, polycrystalline silicon and thin-film without grounding
B	Inverter	SG285HX / SG320HX / SG333HX / SG350HX

Item	Description	Note
C	Transformer	Raises the output voltage of the inverter to a level that meets the requirements of the grid
D	Utility grid	The grid form supported by the inverter is shown in the figure below

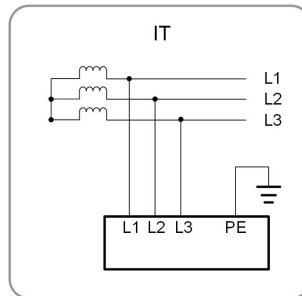

## 2.2 Product Introduction

### Model Description

The model description is as follows (take SG350HX as an example).

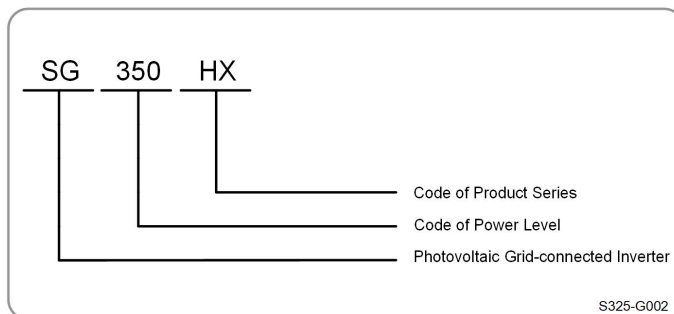

### Appearance

The following figure shows the appearance of the inverter.

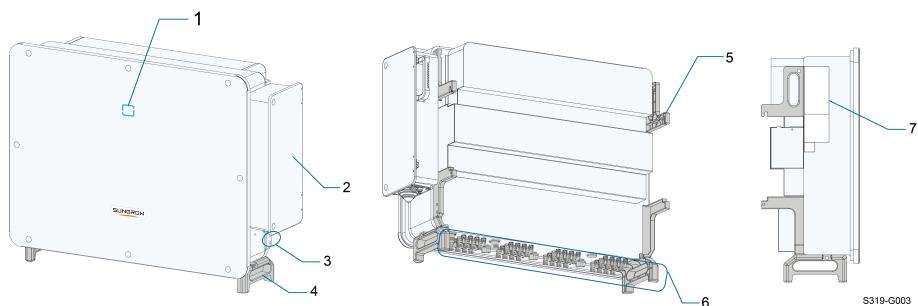

figure 2-2 Appearance

The image shown here is for reference only. The actual product received may differ.



No.	Name	Description
1	LED indicator	To indicate the current working state of the inverter.
2	AC junction box	To connect AC cable and tracking system power cable in this area.
3	External protective grounding terminals	2, use at least one of them to ground the inverter.
4	Bottom handles	2, used to move the inverter.
5	Mounting lugs	4, used to hang the inverter onto the mounting-bracket.
6	Wiring area	DC switches, DC terminals, and communication terminals. For details, refer to "5.2 Terminal Description".
7	Labels	To clearly identify the product, including nameplate, warning symbols and QR code.

### Dimensions

The following figure shows the dimensions of the inverter.

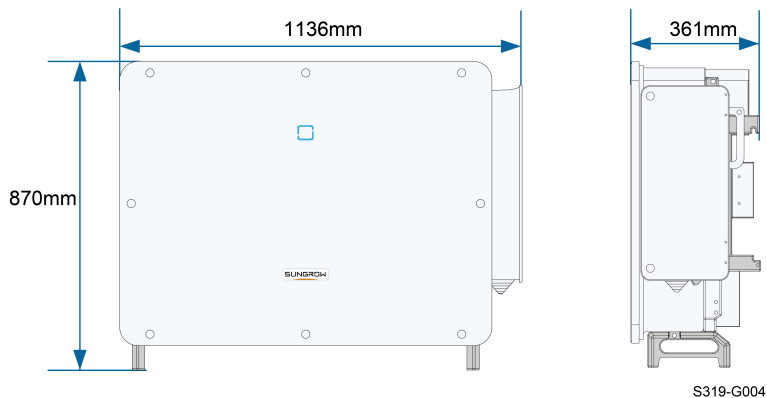









figure 2-3 Product Dimensions(in mm)

### Weight

Model	Weight
SG285HX / SG320HX / SG333HX / SG350HX	≤ 116 kg

## 2.3 Symbols on Product



Symbol	Explanation
	Do not dispose of the inverter together with household waste.
	Read the user manual before maintenance!



Symbol	Explanation
	TUV mark of conformity.
	CE mark of conformity. EU/EEA Importer
	UKCA mark of conformity. The height of the label should not exceed 5 mm.
	Disconnect the inverter from all the external power sources before maintenance!
	Burn danger due to the hot surface that may exceed 60°C.
	Danger to life due to high voltages! Do not touch live parts for 25 minutes after disconnection from the power sources. Only qualified personnel can open and maintain the inverter.
	External protective grounding terminal.

## 2.4 LED Indicator

The LED indicator on the front of the inverter indicates the working state of the inverter.

table 2-1 LED Indicator State Description

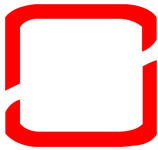
LED Color	State	Definition
 Blue	On	The device is connected to the grid and operating normally.
	Fast blink (Period: 0.2s)	The Bluetooth connection is established, and there is data communication.
	 No system fault occurs.	
	Slow blink (Period: 2s)	The device is in standby or startup state (not feeding power into the grid).
		
	Slow blink once, fast blink three times	The inverter is performing PID recovery.

LED Color	State	Definition
 Red	On	A fault occurs and the device cannot connect to the grid.
	Blink	The Bluetooth connection is established, data communication in process, and a system fault occurs.
 Gray	OFF	Both the AC and DC sides are powered down.

**⚠ WARNING**

**Voltage may still be present in AC side circuits after the indicator is off. Pay attention to the electricity safety when operating.**

## 2.5 DC Switch

The inverter is equipped with four DC switches which can safely disconnect it from PV strings. Each switch controls the DC terminals in the area where the switch is located.

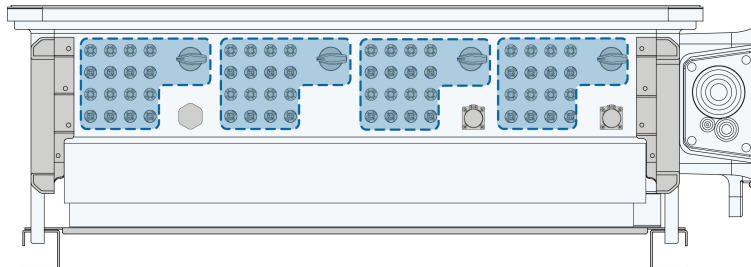

## 2.6 Circuit Diagram

The following figure shows the main circuit of the inverter.

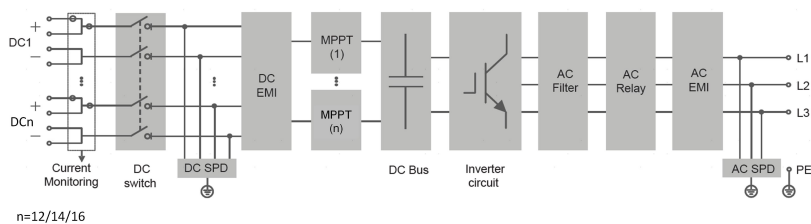

**figure 2-4** Circuit Diagram

- DC Switches can safely disconnect the PV input when necessary to ensure the safe operation of the inverter and the safety of personnel.
- The DC SPD provides a discharge circuit for the DC side overvoltage to prevent it from damaging the internal circuits of the inverter.
- EMI filters can filter out the electromagnetic interference inside the inverter to ensure that the inverter meets the requirements of electromagnetic compatibility standards.
- The MPPT is used to ensure a maximum power from PV arrays at different PV input conditions.
- The Inverter Circuit converts the DC power into grid-compliant AC power and feeds it into the grid.
- The AC filter filters the output AC component of high frequency to ensure that the output current meets the grid requirements.
- The AC relay isolates the AC output of the inverter from the grid, making the inverter safe from the grid in case of inverter failure or grid failure.
- The AC SPD provides a discharge circuit for the AC side overvoltage to prevent it from damaging the internal circuits of the inverter.

**⚠ DANGER**

**If the lightning level exceeds the protection level of the product, surge protection and overvoltage protection may fail, resulting in electric shock and fatal injury!**

## 2.7 Function Description

The inverter is equipped with the following functions:

### Conversion Function

The inverter converts the DC current into grid-compatible AC current and feeds the AC current into the grid.

### Data Storage

The inverter logs running information, error records, etc.

### Parameter Configuration

The inverter provides various settable parameters. Users can set parameters via the App to meet the requirements and optimize the performance.

### Communication Interface

The inverter is designed with standard RS485 communication interfaces.

The standard RS485 communication interfaces are used to establish communication connection with monitoring devices and upload monitoring data by using communication cables. After communication connection is established, users can view inverter information or set inverter parameters through the iSolarCloud.

### Protection Function

The protective functions are integrated in the inverter, including anti-island protection, LVRT, DC reverse connection protection, AC short circuit protection, leakage current protection, surge protection, etc.

### Potential Induced Degradation (PID) (Optional)

The PID effect (Potential Induced Degradation) of PV modules will cause serious damage to PV yield. Through enabling the Anti-PID function, the PID can be suppressed, and this function works when the inverter is in grid-connected operation status during the day or the reactive power generation at night is enabled. Through enabling the PID recovery function, the adverse effects caused by PID can be recovered, and this function only works when the DC side of the inverter is voltage-free.

The working strategy varies with PV panel types.

- P-type panel

When the anti-PID function is enabled, the inverter rises the potential of the negative pole of PV array of P-type panels to close to the ground potential through PID module to suppress PID effect.

When the PID recovery function is enabled, the inverter rises the potential between the negative pole of PV array of P-type panels and the ground to 500Vdc through PID module, to repair the PID effect.

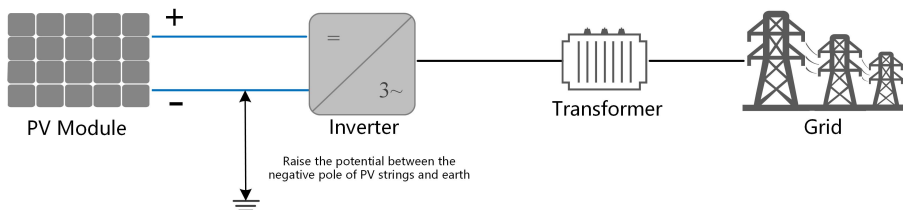

- N-type panel

The electric power engineering company and the user should confirm with the PV panel manufacturer the compensation voltage direction against PID of the selected panel when designing the plant.

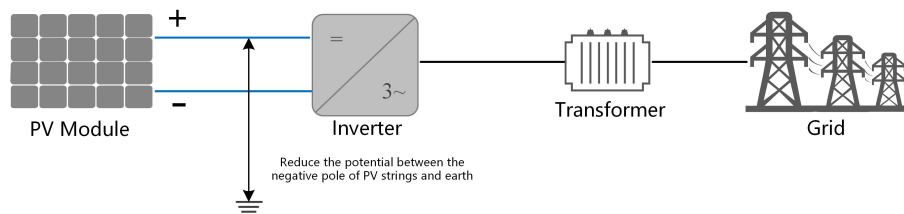

- Make sure the inverter is applied to an IT system before enabling the anti-PID function.
- PID recovery and Q at night can be enabled at the same time, but can not work at the same time. In the IT system, anti-PID and Q at night can work at the same time.
- After PID recovery is enabled, it only works when the DC side of the inverter is voltage-free.
- After the PID recovery function is enabled, the voltage of the PV string to ground is 500Vdc by default.

#### NOTICE

- **Before enabling the anti-PID function or PID recovery function, make sure the voltage polarity of the PV modules to ground meets requirement. If there are any questions, contact the PV module manufacturer or read the corresponding user manual.**
- **If the voltage scheme for the anti-PID function or PID recovery function does not meet the requirement of corresponding PV modules, the PID will not work as expected or even damage the PV modules.**
- **When the PID recovery works (the indicator blinks blue once at long intervals and three times at short intervals), disable the PID recovery function on iSolar-Cloud App before manually powering on and maintaining the inverter.**

## 3 Unpacking and Storage

### 3.1 Unpacking and Inspection

The product is thoroughly tested and strictly inspected before delivery. Nonetheless, damage may still occur during shipping. For this reason, please conduct a thorough inspection after receiving the product.

- Check the packing case for any visible damage.
- Check the scope of delivery for completeness according to the packing list.
- Check the inner contents for damage after unpacking.

Contact SUNGROW or the transport company in case of any damage or incompleteness, and provide photos to facilitate services.

Do not dispose of the original packing case. It is recommended to store the device in the original packing case when the product is decommissioned.

#### NOTICE

- **After receiving the product, check whether the appearance and structural parts of the device are damaged, and check whether the packing list is consistent with the actual ordered product. If there are problems with the above inspection items, do not install the device and contact your distributor first. If the problem persists, contact SUNGROW in time.**
- **If any tool is used for unpacking, be careful not to damage the product.**

### 3.2 Unpacking Steps

step 1 Use a utility knife to cut the packing tape. Remove horizontal and vertical paper angle beads.

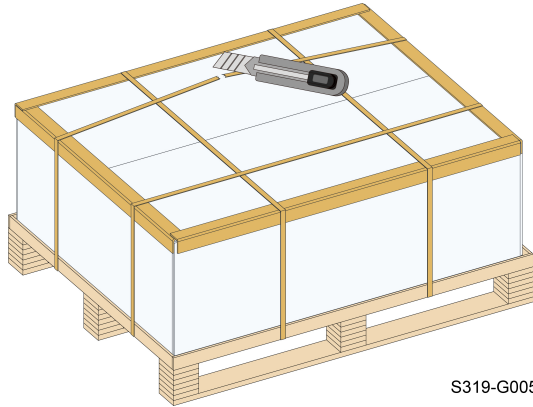

S319-G005

step 2 Remove the packing box upwards.

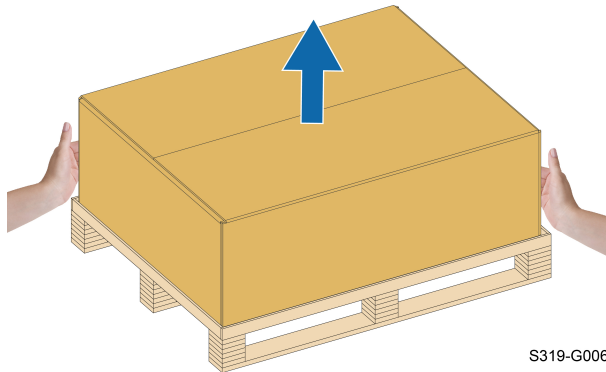

S319-G006

step 3 Remove the surrounding paper angle beads.

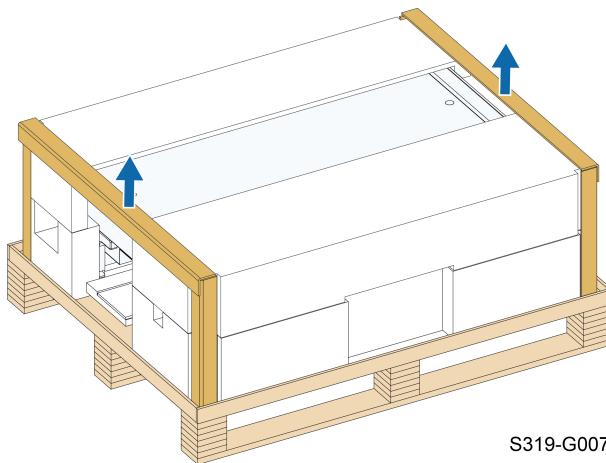

S319-G007

step 4 Remove the upper cushion.



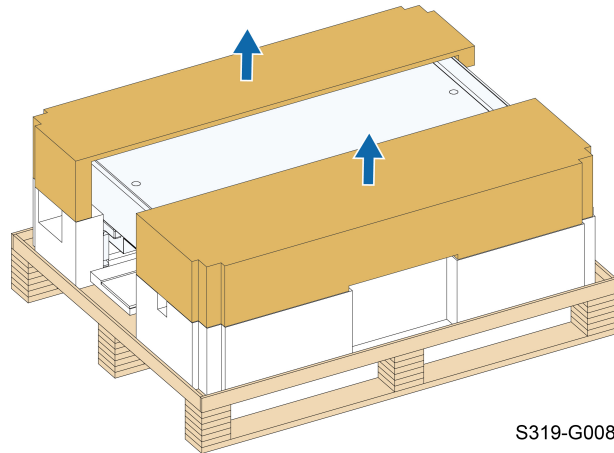

-- End

### 3.3 Inverter Storage

Proper storage is required if the inverter is not installed immediately.

- Store the inverter in the original packing case with the desiccant inside.
- The storage temperature must be always between  $-40^{\circ}\text{C}$  and  $+70^{\circ}\text{C}$ , and the storage relative humidity must be always between 0 and 95 %, non-condensing.
- In case of stacking storage, the number of stacking layers should never exceed the limit marked on the outer side of the packing case.
- The packing case should be upright.
- If the inverter needs to be transported again, pack it strictly before loading and transporting it.
- Do not store the inverter in places susceptible to direct sunlight, rain, and strong electric field.
- Do not place the inverter in places with items that may affect or damage the inverter.
- Store the inverter in a clean and dry place to prevent dust and water vapor from eroding.
- Do not store the inverter in places with corrosive substances or susceptible to rodents and insects.
- Carry out periodic inspections. Inspection shall be conducted at least once every six months. If any insect or rodent bites are found, replace the packaging materials in time.
- If the inverter has been stored for more than a year, inspection and testing by professionals are required before it can be put into operation.

#### NOTICE

**Please store the inverter according to the storage requirements. Product damage caused by failure to meet the storage requirements is not covered by the warranty.**

## 4 Mechanical Mounting

### WARNING

Respect all local standards and requirements during mechanical installation.

### 4.1 Safety During Mounting

#### DANGER

Make sure there is no electrical connection before installation.  
Before drilling, avoid the water and electricity wiring in the wall.

#### WARNING

Poor installation environment will affect system performance!

- Install the inverter in a well-ventilated place.
- Ensure that the heat dissipation system or vent is not blocked.
- Do not install the inverter in an environment with flammable and explosive objects or smoke.

#### CAUTION

Improper handling may cause personal injury!

- When moving the inverter, be aware of its weight and keep the balance to prevent it from tilting or falling.
- Wear proper protective equipment before performing operations on the inverter.
- The bottom terminals and interfaces of the inverter cannot directly contact the ground or other supports. The inverter cannot be directly placed on the ground.

#### NOTICE

When installing devices, ensure that no device in the system causes it hard for the DC switch and the AC circuit breaker to act or hinders maintenance personnel from operating.

If drilling is required during installation:

- Wear goggles and protective gloves when drilling holes.
- Make sure to avoid the water and electricity wiring in the wall before drilling.
- Protect the product from shavings and dust.

## 4.2 Location Requirements

To a large extent, a proper installation location ensures safe operation, service life, and performance of the inverter.

- The inverter with protection rating IP66 can be installed both indoors and outdoors.
- The inverter should be installed at a height that allows easy viewing of the LED indicator panel, as well as easy electrical connection, operation and maintenance.

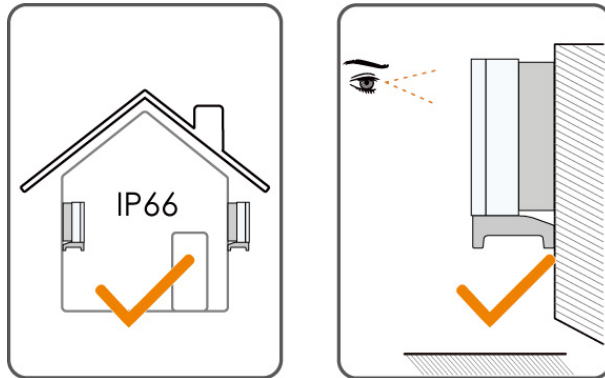

### 4.2.1 Environment Requirements

- The installation environment must be free of inflammable or explosive materials.
- The location should not be accessible to children.
- The ambient temperature and relative humidity must meet the following requirements.

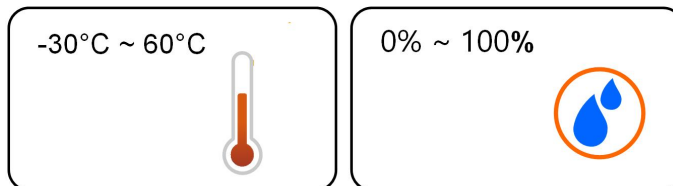

- Please consult SUNGROW before installing inverters outdoors in salt stress areas. Salt stress areas mainly refer to coastal areas that are within 500 meters from the coast. The deposition of salt fog varies largely with nearby seawater characteristics, sea wind, precipitation, relative humidity, terrain, and forest coverage.
- Install the inverter in a sheltered area to avoid direct sunlight and bad weather (e.g. snow, rain, lightning, etc.). The inverter will derate in high temperature environments for protection. If the inverter is installed in direct sunlight, it may cause power reduction as the temperature rises.
- It is strictly forbidden to install the inverter in an environment with strong vibration or electromagnetic field.
- The inverter should be well ventilated. Ensure air circulation.
- The inverter generates noise during operation and is not recommended to be installed in living areas.

- The inverter should be installed more than 30 m away from third-party wireless communication facilities and living areas.

#### 4.2.2 Carrier Requirements

The mounting structure where the inverter is installed must comply with local/national standards and guidelines. Ensure that the installation surface is solid enough to bear four times the weight of the inverter and is suitable for the dimensions of the inverter (e.g. cement walls, plasterboard walls, etc.).

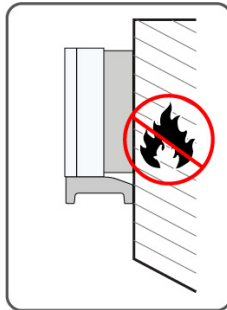

#### 4.2.3 Angle Requirements

Install the inverter vertically or tilt backwards. Do not install the inverter horizontally, forward, excessively backward, sideways, or upside down.

Inverters in floating plants cannot be installed at a back tilt.

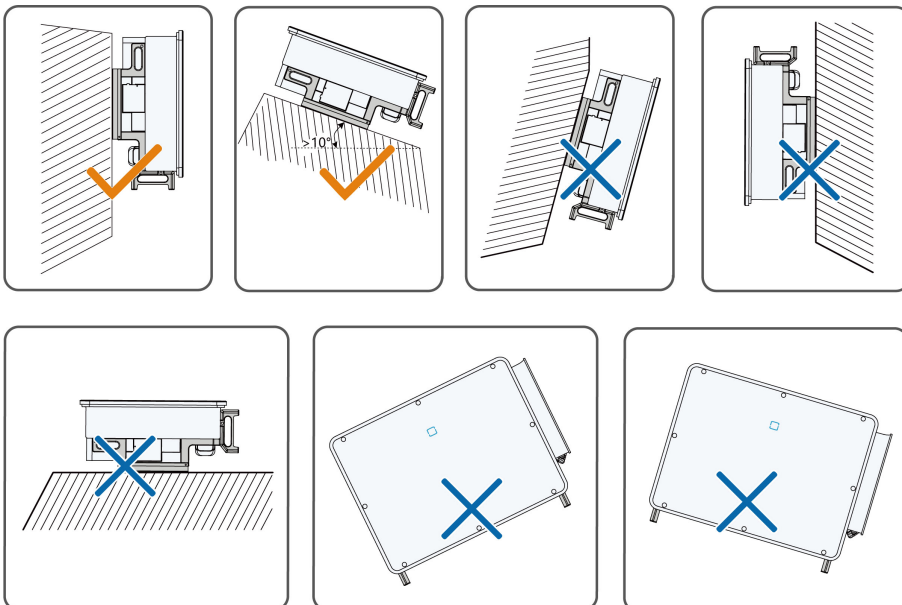

In case the installation site is a level surface, mount the inverter to the bracket to meet the mounting angle requirements, as shown in the figure below.

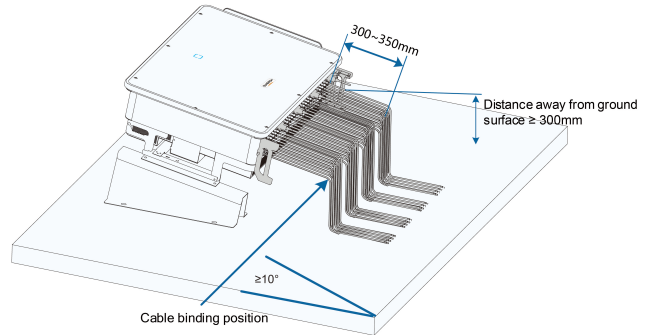

Take the following items into account when designing the bracket scheme:

- Consider onsite climate conditions and take anti-snow and anti-rain measures if necessary.
- Ensure that the waterproof connectors are at least 300 mm higher than the ground surface.
- Bind the cables at the positions 300~350 mm away from the DC connector, AC waterproof terminal, and communication waterproof terminal.
- The various waterproof terminals should be tightened with the torque specified in this manual to ensure that they are securely sealed.

Contact SUNGORW if you have any question.

#### 4.2.4 Clearance Requirements

Reserve enough clearance around the inverter to ensure sufficient space for heat dissipation.

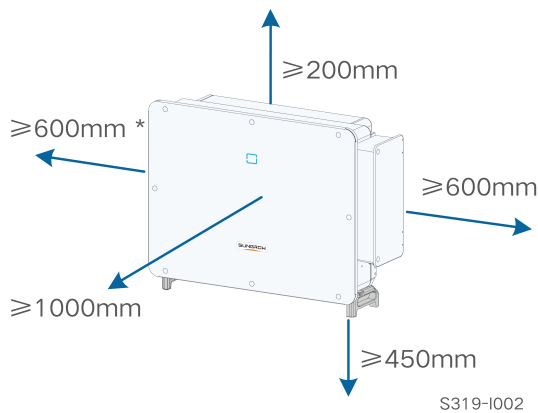

\* In case this distance is less than the distance in the diagram, move the inverter from the mounting-bracket or wall before maintaining fans.

The AC cable should be at least vertically led into the AC terminal, and the straight length should be  $\geq 200$  mm.

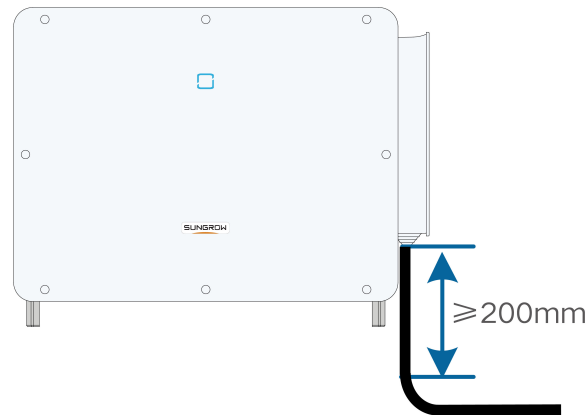

In case of multiple inverters, reserve specific clearance between the inverters.



S319-004

### Back-to-Back Installation

When installing inverters back-to-back, the distance between every two inverters should be at least 600 mm (recommended).

If the on-site distance is shorter than the recommended clearance, add a baffle between every two inverters to form a heat dissipation channel (not recommended). The baffle plate should be placed horizontally between two inverters and should not block the air inlet and outlet of inverters.

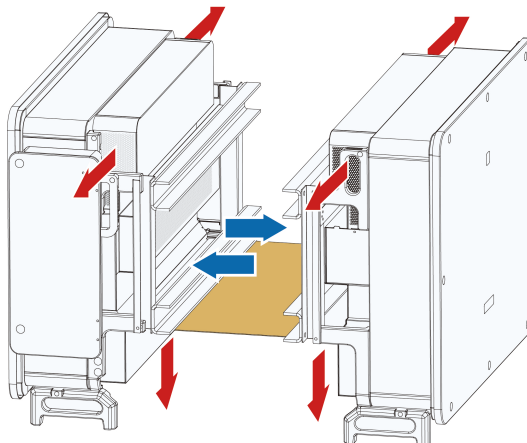

### 4.3 Installation Tools

Installation tools include but are not limited to the following recommended ones. If necessary, use other auxiliary tools on site.

table 4-1 Tool specification

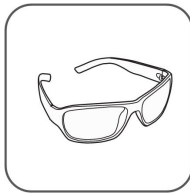

Goggles

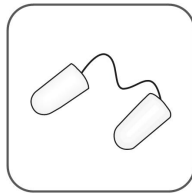

Earplugs

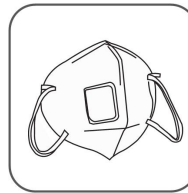

Dust mask



Protective gloves



Insulated shoes

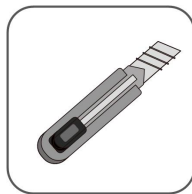

Utility knife



Slotted screwdriver  
(M2, M3, M6)



Phillips screwdriver  
(M4, M6, M8)



Hammer drill  
( $\phi 12$ )



Pliers

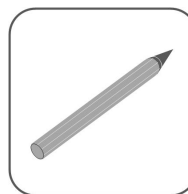

Marker

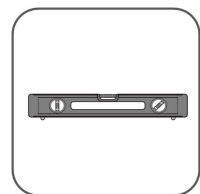

Level

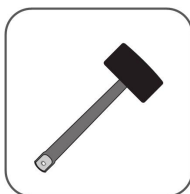

Rubber mallet



Socket wrench set  
(M4, M8, M12)

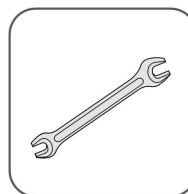

Wrench  
(16 mm, 35 mm)

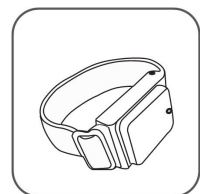

Wrist strap

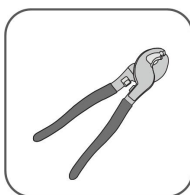

Wire cutter

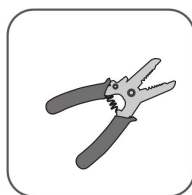

Wire stripper

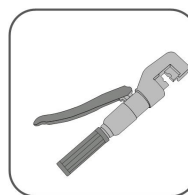

Hydraulic plier

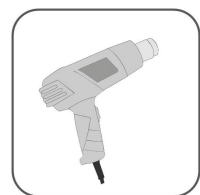

Heat gun



MC4-Evo2 terminal  
crimping pliers  
4–6mm<sup>2</sup>

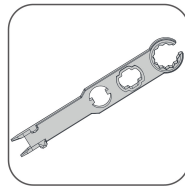

MC4-Evo2 terminal  
wrench

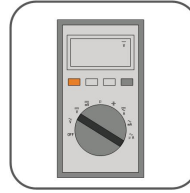

Multimeter  
(≥ 1500 Vdc)



Vacuum cleaner



Scissors

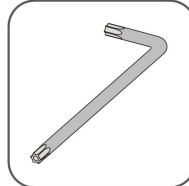

Hexagon socket  
wrench  
(T30)

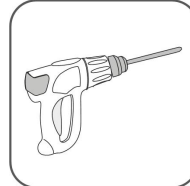

Electric drill  
(φ12)

## 4.4 Moving Inverter

Move the inverters by carrying them manually or using a hoisting tool based on site conditions.

### ⚠ CAUTION

**Improper handling may cause personal injury!**

- Arrange an appropriate number of personnel to carry the inverter according to its weight, and installation personnel should wear protective equipment such as anti-impact shoes and gloves.
- Attention must be paid to the center of gravity of the inverter to avoid tilting during handling.
- Placing the inverter directly on a hard ground may cause damage to its metal enclosure. Protective materials such as sponge pad or foam cushion should be placed underneath the inverter.
- Move the inverter by holding the handles on it. Do not move the inverter by holding the terminals.

### 4.4.1 Manual Transport

Install the four screw-in handles that are provided to the inverter lugs and the base. Lift and move the inverter to the destination by holding the bottom handles and the four installed handles.

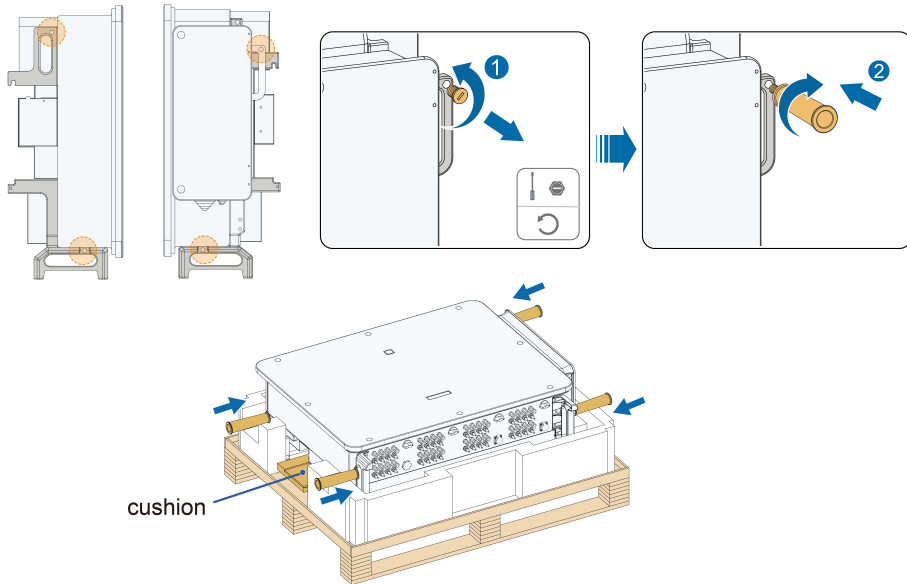

**NOTICE**

**When handling the inverter, do not remove the cushion to avoid damage to the housing or bottom terminals.**

**4.4.2 Hoisting Transport****Tools**

Device Name	Requirement	Source
Crane	Load bearing capacity $\geq$ 180 kg	Not included in the scope of delivery
Lifting ring	2, M12, load bearing capacity of a single ring $\geq$ 260 kg	Not included in the scope of delivery
Sling	1, length $\geq$ 2.5 m, load bearing capacity of a single sling $\geq$ 600 kg	Not included in the scope of delivery

step 1 Release the sealing screws on the mounting lugs and store them properly. Anchor two M12 thread lifting rings to the lugs of the inverter.

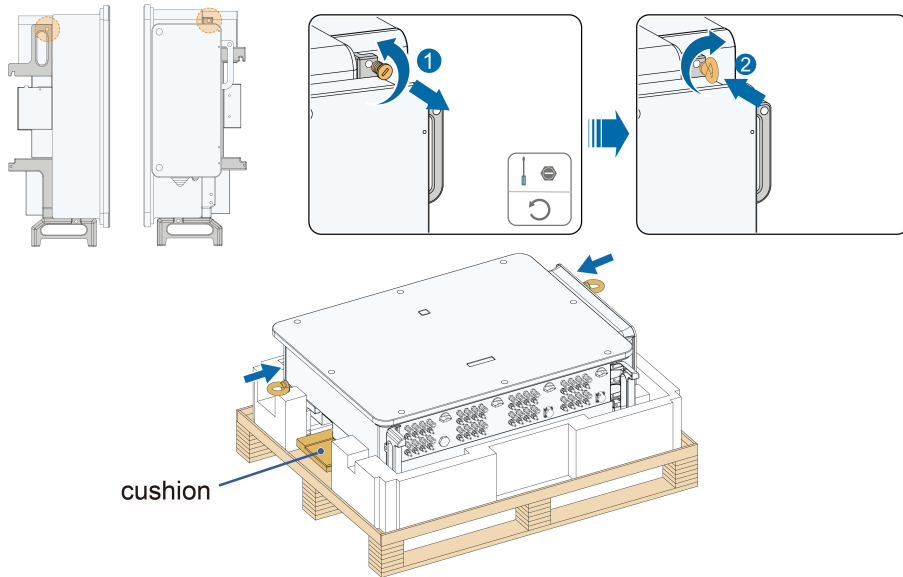
**NOTICE**

**When handling the inverter, do not remove the cushion to avoid damage to the housing or bottom terminals.**

- step 2 Lead the sling through the two lifting rings and fasten the tie-down strap.
- step 3 Hoist the inverter, and stop to check for safety when the inverter is 100 mm above the ground. Continue hoisting the device to the destination after ensuring the safety.

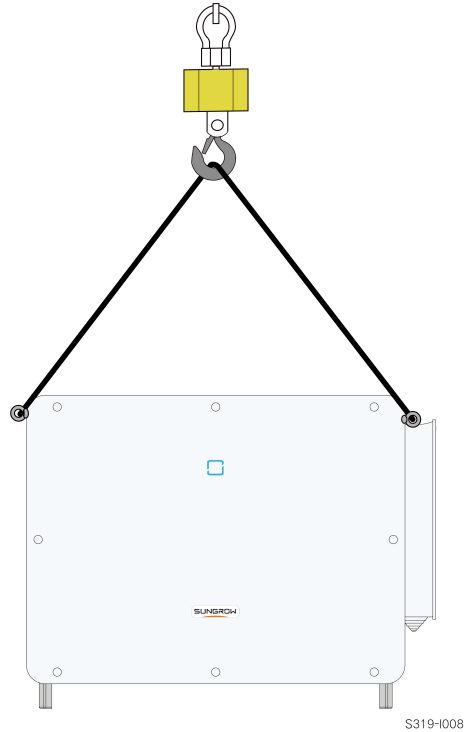

step 4 Remove the lifting rings and reassemble the sealing screws released in Step 1.

**⚠ CAUTION**

**Keep the inverter balanced throughout the hoisting process and avoid collisions with walls or other objects. Stop hoisting in the event of severe weather, such as heavy rain, thick fog, or strong wind.**



The lifting rings and the sling are not within the delivery scope.

-- End

## 4.5 Installing Mounting-bracket

The inverter can be installed on a bracket, a wall, and a pole by means of mounting-bracket. Dimensions of the assembled mounting-bracket are as follows.

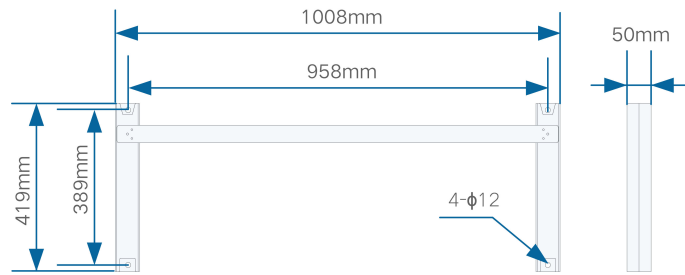
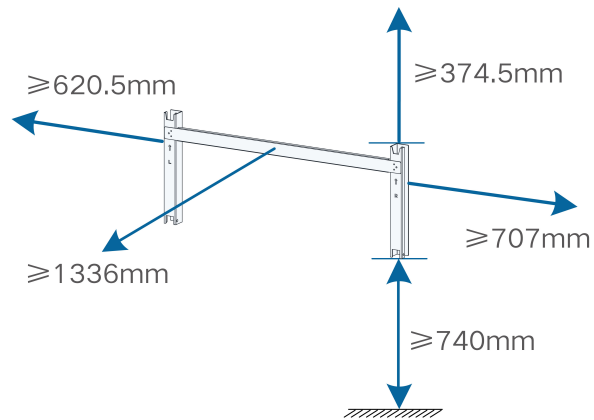

figure 4-1 Dimensions of Mounting-bracket

Reserve enough space when installing the mounting-bracket to meet the installation space requirements of the inverter.



#### 4.5.1 Bracket-Mounted Installation

Tools

Item	Specification
Phillips screwdriver	M4
Marker	-
Level	-
Electric drill	Drill bit: $\phi 12$
Wrench	Opening: 16 mm

Spare parts

Item	Quantity	Specification	Source
Grub screw	2	M4×10	Delivery scope
Bolt assembly	4	M10	Delivery scope

step 1 Assemble the mounting-bracket.

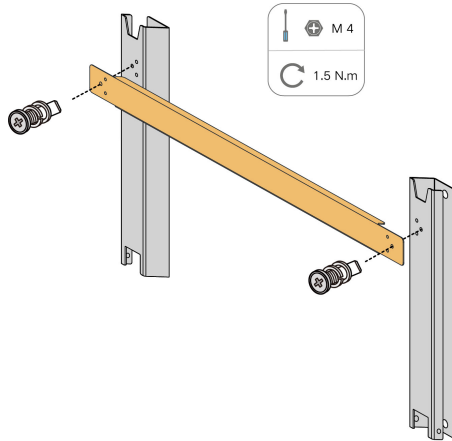

step 2 Place the assembled mounting-bracket onto the PV bracket. Adjust the angle with a level and mark positions for drilling holes. Drill the holes by using an electric drill.

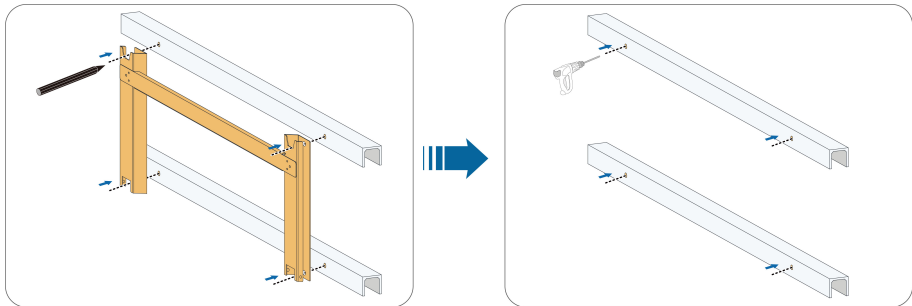

S319-I011

step 3 Secure the mounting-bracket with bolts.

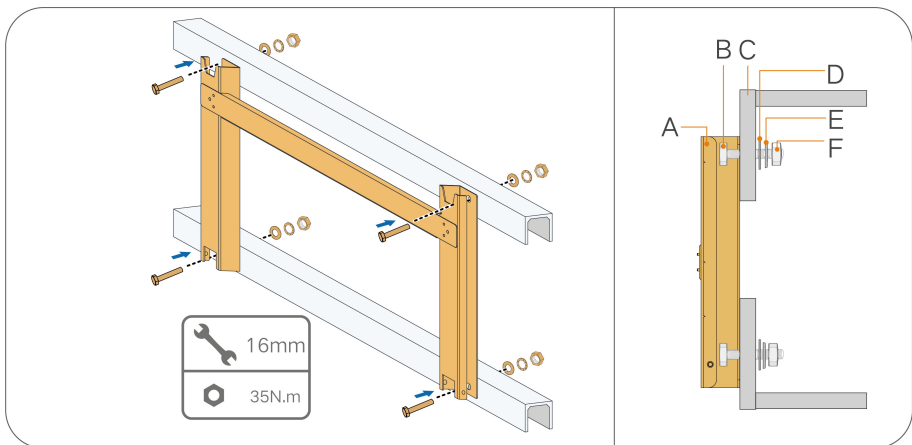

(A) Mounting-bracket (B) Full threaded bolt  
(D) Flat washer (E) Spring washer

(C) Metal bracket  
(F) Hex nuts

-- End

## 4.5.2 Wall-Mounted Installation

### Tools

Item	Specification
Phillips screwdriver / electric screw driver	M4
Marker	-
Level	-
Hammer drill	Drill bit: $\varnothing 12$
Wrench	Opening: 16 mm

### Spare parts

Item	Quantity	Specification	Source
Grub screw	2	M4×10	Delivery scope
Expansion bolt	11	M10×95 (Recommended)	Self-prepared
Baffle plate	3	—	Self-prepared

step 1 Assemble the mounting-bracket.

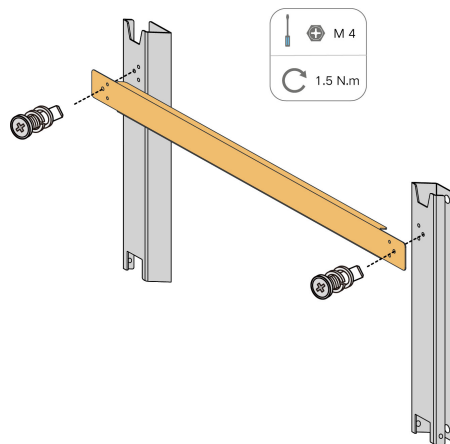

step 2 Level the assembled mounting-bracket by using the level, and mark the positions for drilling holes.

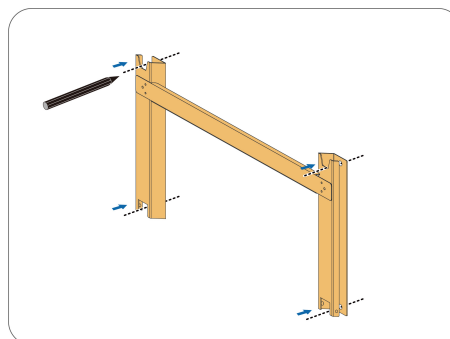

S319-I013

step 3 Drill the holes by using a hammer drill. Insert the expansion bolts into the holes and secure them with a rubber hammer. Fasten the nut with a wrench to expand the bolt. Remove the nut, spring washer, and flat washer, and store them properly.

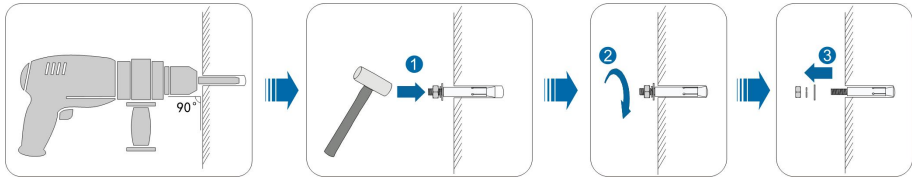

step 4 Install the mounting-bracket to the wall with the expansion bolts with the expansion bolts.

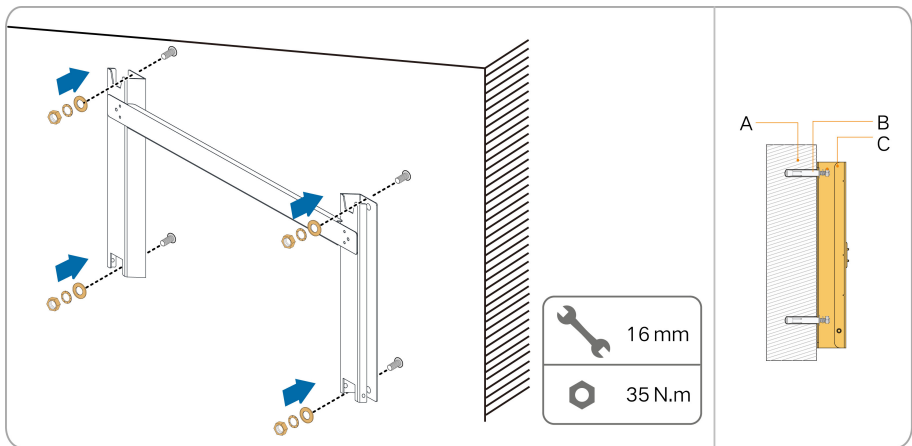

(A) Wall

(B) Expansion bolt

(C) Mounting-bracket

step 5 Fix the baffle plate to the wall with the expansion bolts.

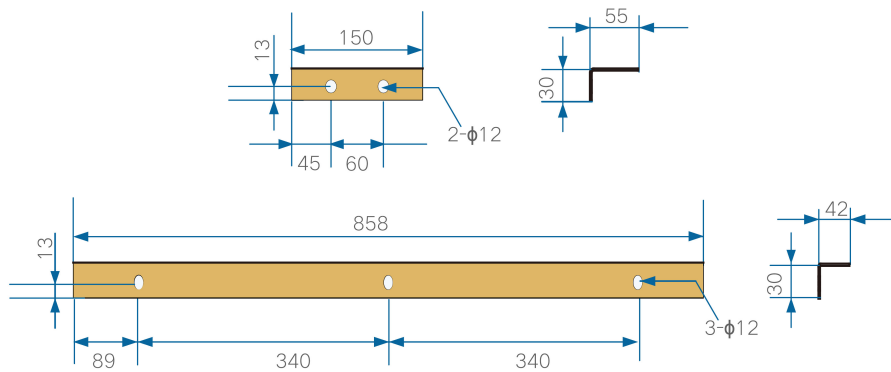

figure 4-2 Dimensions of Baffle Plate (mm)

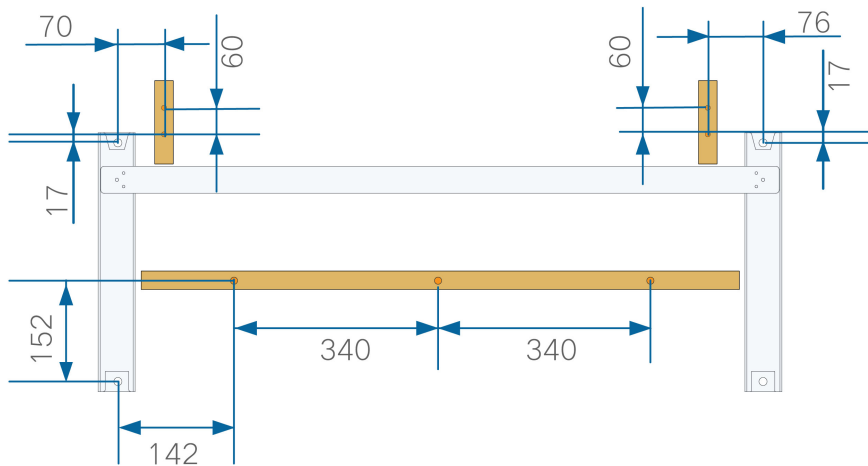

figure 4-3 Relative Distance Between Baffle Plate and Mounting-bracket (mm)

-- End

### 4.5.3 Pole-Mounting

#### Tools

Item	Specification
Phillips screwdriver	M4
Marker	—
Level	—
Electric drill *	Drill bit: $\phi 12$
Wrench	Opening: 16 mm

\* Check whether other tools are needed according to the specification of clamp bolts.

#### Spare parts



Item	Quantity	Specification	Source
Grub screw	2	M4×10	Delivery scope
Bolt assembly	4	M10	Delivery scope
Nut assembly	4	M10	Self-prepared
U-beam	2	—	Self-prepared
Clamp	2	Determined by pole size	Self-prepared

step 1 Bury the pole into the installation site.



Please skip this step if the inverter is to be installed on a concrete post, PV bracket, etc.

step 2 Assemble the mounting-bracket.

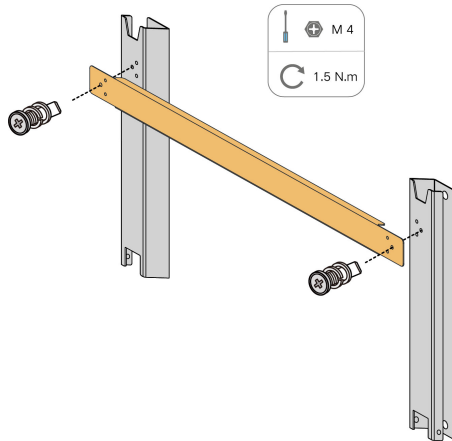

step 3 Mark and punch holes in the U-beam according to the dimensions shown below.

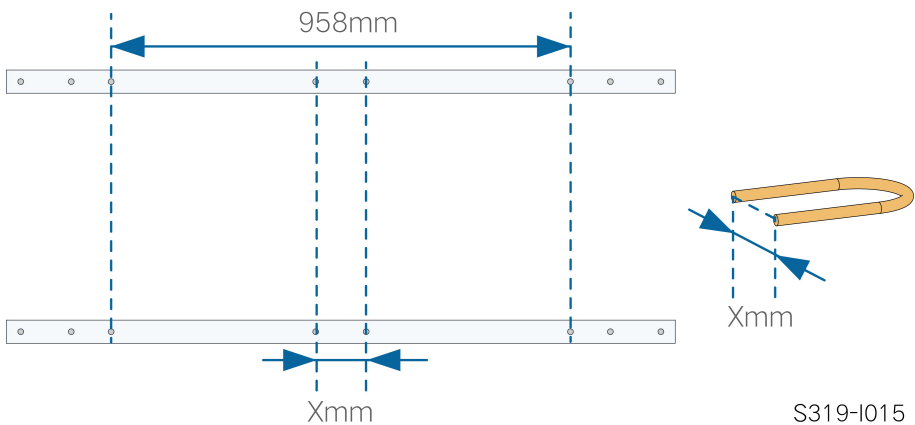

S319-I015

step 4 Use bolts and clamps to fix the U-beam to the pole.

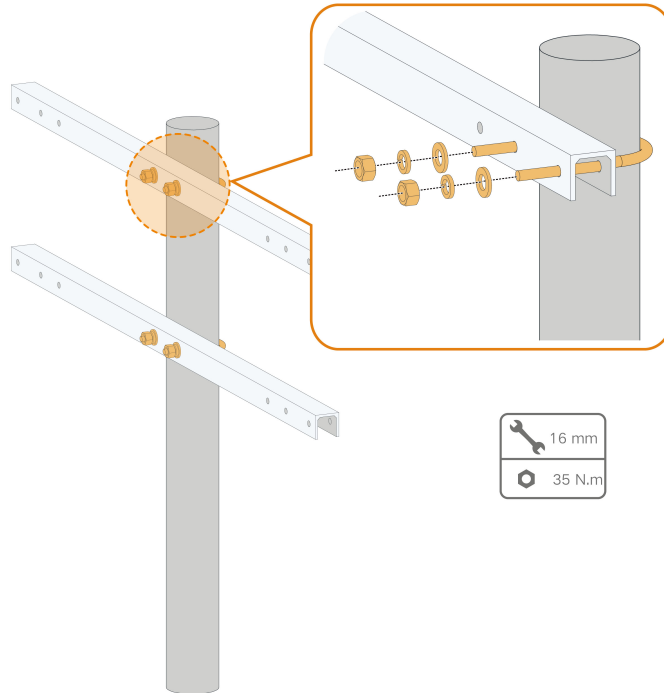

step 5 Use bolts to secure the mounting-bracket to the U-beam.

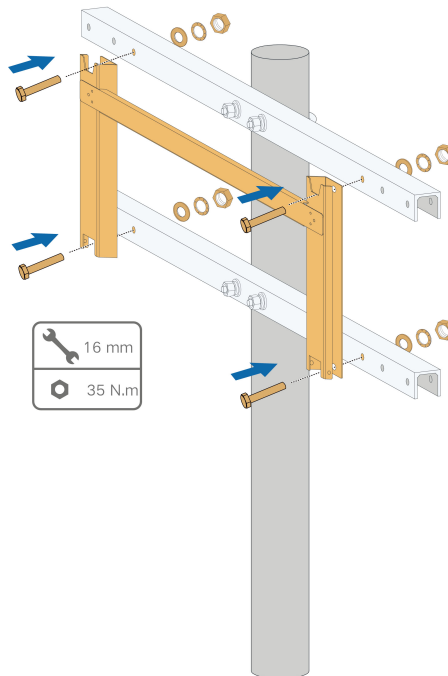

-- End

## 4.6 Installing the Inverter

### Tools

Item	Specification
Phillips screwdriver	M6

### Spare parts

Item	Quantity	Specification	Source
Grub screw	2	M6×65	Delivery scope

- step 1 If the installation position is high, hoist the inverter to the position (refer to "4.4.2 Hoisting Transport"). Otherwise, skip this step.
- step 2 Remove the bottom cushion and lift the inverter onto the mounting-bracket. Make sure that the mounting lugs fit well into the grooves of the mounting-bracket.

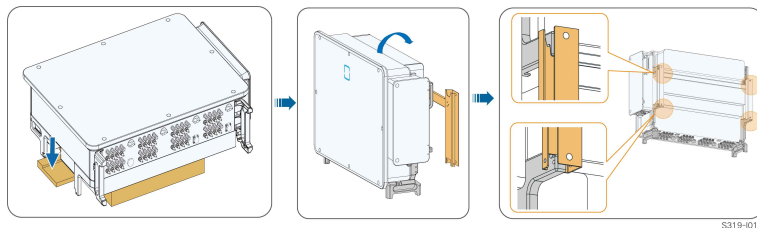

- step 3 Fix the inverter with screws.

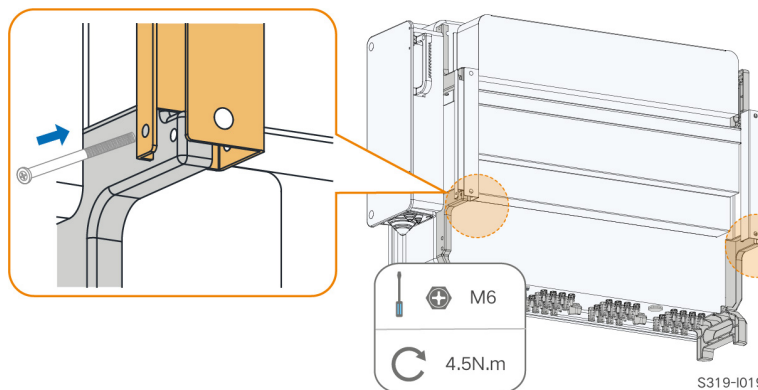

### NOTICE

It is necessary to secure the left and right sides of the inverter to the mounting-bracket with screws, otherwise the inverter may become unstable.

-- End

# 5 Electrical Connection

## 5.1 Safety Instructions

### DANGER

The PV string will generate lethal high voltage when exposed to sunlight.

- Operators must wear proper personal protective equipment during electrical connections.
- Must ensure that cables are voltage-free with a measuring instrument before touching DC cables.
- Respect all safety instructions listed in relevant documents about PV strings.

### DANGER

- Before electrical connections, please make sure that the inverter switch and all switches connected to the inverter are set to "OFF", otherwise electric shock may occur!
- Ensure that the inverter is undamaged and all cables are voltage free before performing electrical work.
- Do not close the AC circuit breaker until the electrical connection is completed.

### WARNING

Damage to the product caused by incorrect wiring is not covered by the warranty.

- Electrical connection must be performed by professionals.
- Operators must wear proper personal protective equipment during electrical connections.
- All cables used in the PV generation system must be firmly attached, properly insulated, and adequately dimensioned. Cables used shall comply with the requirements of local laws and regulations.
- The factors that affect cable selection include rated current, cable type, routing mode, ambient temperature, and maximum expected line loss.

**⚠ WARNING**

- **Do not damage the ground conductor. Do not operate the product in the absence of a properly installed ground conductor. Otherwise, it may cause personal injury or product damage.**
- **Please use measuring devices with an appropriate range. Overvoltage can damage the measuring device and cause personal injury.**

**NOTICE**

**All electrical connections must comply with local and national/regional electrical standards.**

- **Cables used by the user shall comply with the requirements of local laws and regulations.**
- **Only with the permission of the national/regional grid department, the inverter can be connected to the grid.**

**NOTICE**

- **Install the external protective grounding cable first when performing electrical connection and remove the external protective grounding cable last when removing the inverter.**
- **Comply with the safety instructions related to PV strings and the regulations related to the utility grid.**

**NOTICE**

- **After being crimped, the OT terminal must wrap the wires completely, and the wires must contact the OT terminal closely.**
- **When using a heat gun, protect the device from being scorched.**
- **Before connecting a power cable (such as the AC cable, the DC cable, etc.), confirm that the label and identifier on the power cable are correct.**
- **When laying out communication cables, separate them from power cables and keep them away from strong interference sources to prevent communication interruption.**
- **All vacant terminals must be covered with waterproof covers to prevent affecting the protection performance.**
- **Ensure that AC output cables are firmly connected. Failing to do so may cause inverter malfunction or damage to its AC connectors.**
- **When the wiring is completed, seal the gap at the cable inlet and outlet holes with fireproof/waterproof materials such as fireproof mud to prevent foreign matter or moisture from entering and affecting the long-term normal operation of the inverter.**



The cable colors in figures in this manual are for reference only. Please select cables according to local cable standards.

## 5.2 Terminal Description

All electrical terminals are located at the side and bottom of the inverter.

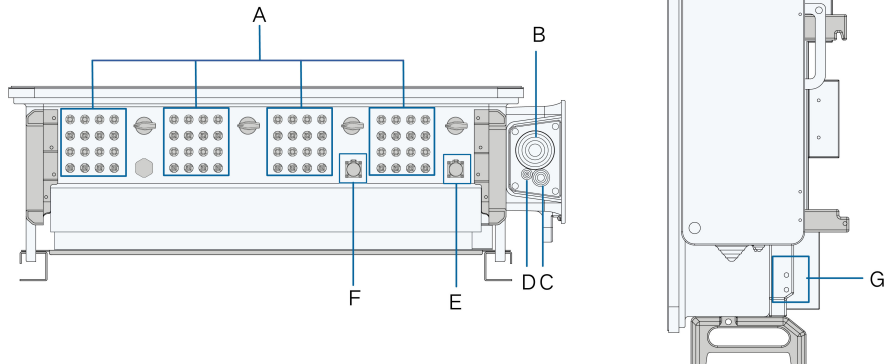

**figure 5-1** Terminal Description (One Wire per Phase with Multi-core Cable)

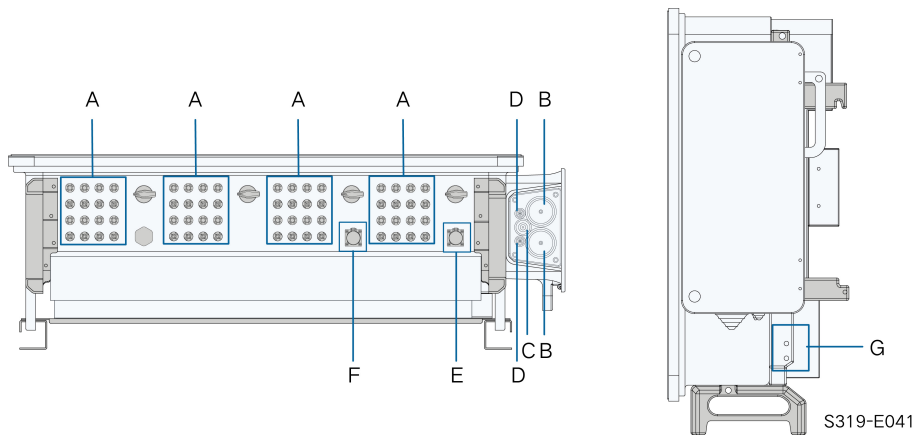

**figure 5-2** Terminal Description (Two Wires per Phase with Multi-core Cable)

\* The image shown here is for reference only. The actual product received may differ.

Item	Terminal	Mark	Note
			24 / 28 / 32, PV connector
A	PV terminals	+ / -	The number of PV terminals varies, subject to actual product received
B	AC wiring terminal	—	Used for AC output cable connection.
C	Standby grounding terminal	—	If the PE cable is an independent single-core cable, it should be led into the AC junction box for cable wiring through the standby grounding terminal
D	Tracker terminal	—	For the power cord wiring of the Tracking system

Item	Terminal	Mark	Note
E	Communication terminal	COM1	For RS485 communication wiring.
F	Communication terminal	COM2	Optional, DI/DO and CAN wiring, etc Communication terminal COM2 is optional, subject to actual product received
G	External protective grounding terminal		For reliable grounding 2, use at least one of them to ground the inverter.

### 5.3 Electrical Connection Overview

Electrical connection in the PV system includes external grounding connection, AC connection, and PV string connection.

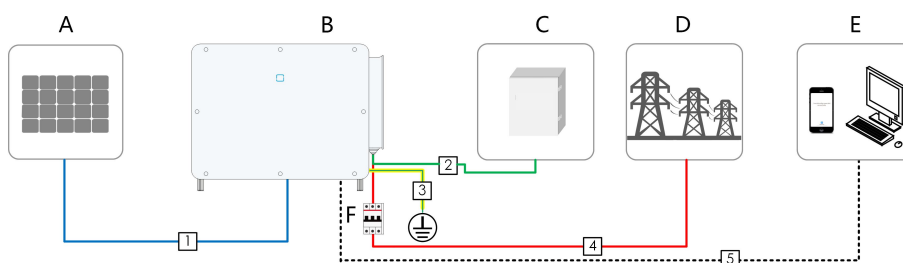

(A) PV string

(B) Inverter

(C) Tracking control box

(D) Grid

(E) Monitoring device

(F) AC circuit breaker

table 5-1 Cable Requirements

No.	Cable	Type	Specification	
			Cable Diameter (mm)	Conductor Cross-sectional Area(mm <sup>2</sup> )
1	DC cable	PV cable complying with 1,500V standard	4.7 ~ 6.4	4 ~ 6
2	Tracking system power cable	Outdoor double-core copper wire cable	8 ~ 18	0.5 ~ 10 (Recommended 4 ~ 6)
3	External grounding cable	Outdoor single-core copper wire cable	/	$S_p \geq S/2$



No.	Cable	Type	Specification	
			Cable Diameter (mm)	Conductor Cross-sectional Area(mm <sup>2</sup> )
4	AC cable	One Wire per Phase with Multi-core Cable	Refer to "table 5-2 AC Cable Requirements (One Wire per Phase with Multi-core Cable)"	
		Two Wires per Phase with Multi-core Cable	Refer to "table 5-3 AC Cable Requirements (Two Wires per Phase with Multi-core Cable)"	
5	Communication cable	Shielded twisted pair	4 ~ 11	0.2 ~ 1.3

Note: S is the cross-sectional area of the AC cable conductor, and Sp is the cross-sectional area of the ground cable conductor.

The AC cable sealing plate delivered with the inverter varies. The actual product received shall prevail.

The sealing plate and the required AC cables are as follows.

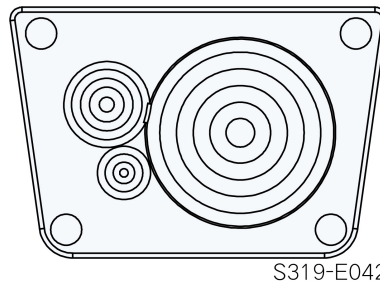

figure 5-3 Sealing Plate for One Wire per Phase with Multi-core Cable

table 5-2 AC Cable Requirements (One Wire per Phase with Multi-core Cable)

No.	Type	Specification	
		Cable Diameter(mm)	Conductor Cross-sectional Area(mm <sup>2</sup> )
1	Outdoor four-core copper / aluminum wire cable <sup>(1)</sup>	Four-core cable: 40 ~ 75	Copper wire: S: 70 ~ 185
2	Outdoor three-core copper / aluminum wire cable <sup>(1)</sup>	Three-core cable: 40 ~ 75	$S_p \geq S/2$
	Outdoor PE cable <sup>(2)</sup>	PE cable: 15 ~ 32	Aluminum wire: S: 70 ~ 400 $S_p \geq S/2$

Note(1) A copper to aluminum adapter terminal is required when an aluminum cable is used. For details, refer to "[Aluminum Cable Requirements](#)".

Note(2) The specifications are valid only when the phase wire and PE wire use the same material. If otherwise, ensure that the cross section of the PE wire produces a conductance equivalent to that of the wire specified in the table.

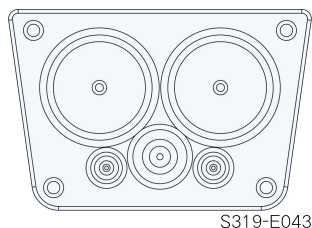

**figure 5-4** Sealing Plate for Two Wires per Phase with Multi-core Cable

table 5-3 AC Cable Requirements (Two Wires per Phase with Multi-core Cable)

No.	Type	Specification	
		Cable Diameter(mm)	Conductor Cross-sectional Area(mm <sup>2</sup> )
1	Outdoor three-core copper wire cable	Three-core cable: 47 ~ 59	Copper/Aluminum wire: S: 120 ~ 185
	Outdoor PE cable <sup>(2)</sup>		
2	Outdoor three-core aluminum wire cable <sup>(1)</sup>	PE cable: 10 ~ 30	$S_p \geq S/2$
	Outdoor PE cable <sup>(2)</sup>		

Note(1) A copper to aluminum adapter terminal is required when an aluminum cable is used. For details, refer to "[Aluminum Cable Requirements](#)".

Note(2) The specifications are valid only when the phase wire and PE wire use the same material. If otherwise, ensure that the cross section of the PE wire produces a conductance equivalent to that of the wire specified in the table.

## 5.4 Crimp OT/DT terminal

### Crimp OT/DT terminal

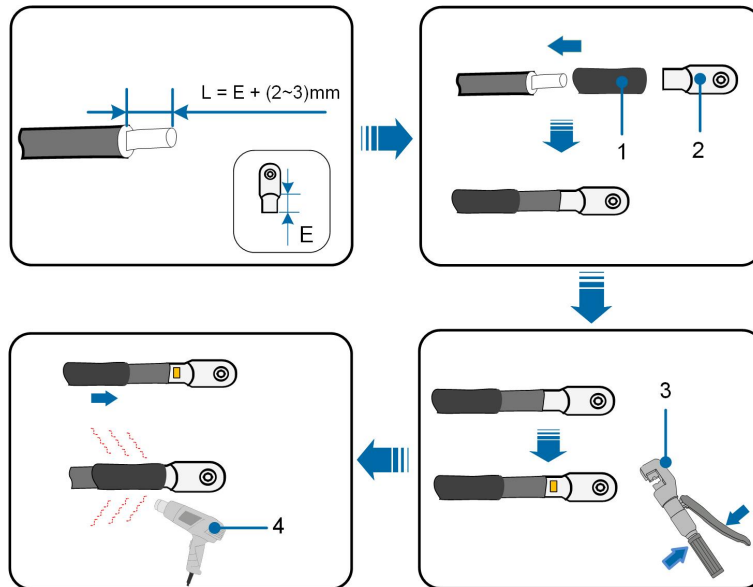

1. Heat shrink tubing

2. OT/DT terminal

3. Hydraulic pliers

4. Heat gun

### Aluminum Cable Requirements

If an Aluminum cable is selected, use a copper to Aluminum adapter terminal to avoid direct contact between the copper bar and the Aluminum cable.

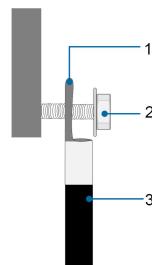

figure 5-5 Aluminum Cable Connection

1. Copper to Aluminum adapter terminal

2. Flange nut

3. Aluminum cable

#### NOTICE

Ensure that the selected terminal can directly contact with the copper bar. If there are any problems, contact the terminal manufacturer.

Ensure that the copper bar is not in direct contact with the aluminum wire. Otherwise, electrochemical corrosion may occur, impairing the reliability of electrical connection.

## 5.5 External Protective Grounding Connection

### DANGER

#### Electric shock!

- **Make sure that the grounding cable is connected reliably. Otherwise, it may cause electric shock.**

### WARNING

- **Since the inverter is not equipped with a transformer, neither the negative electrode nor the positive electrode of the PV string can be grounded. Otherwise, the inverter will not operate normally.**
- **Connect the grounding terminal to the external protective grounding point before AC cable connection, PV string connection, and communication cable connection.**
- **The external protective grounding point provides a reliable ground connection. Do not use an improper grounding conductor for grounding, Otherwise, it may cause product damage or personal injury.**

### WARNING

**The external protective grounding terminal must meet at least one of the following requirements.**

- **The cross-sectional area of the grounding cable is not less than 10 mm<sup>2</sup> for copper wire or 16 mm<sup>2</sup> for aluminum wire. It is recommended that both the external protective grounding terminal and the AC side grounding terminal be reliably grounded.**
- **If the cross-sectional area of the grounding cable is less than 10 mm<sup>2</sup> for copper wire or 16 mm<sup>2</sup> for aluminum wire, ensure that both the external protective grounding terminal and the AC side grounding terminal are reliably grounded.**

**The grounding connection can be made by other means if they are in accordance with the local standards and regulations, and SUNGROW shall not be held liable for the possible consequences.**

### 5.5.1 External Protective Grounding Requirements

All non-current carrying metal parts and device enclosures in the PV power system should be grounded, for example, brackets of PV modules and inverter enclosure.

When there is only one inverter in the PV system, connect the external protective grounding cable to a nearby grounding point.

When there are multiple inverters in the PV system, connect the external protective grounding terminals of all inverters and the grounding points of the PV module brackets to ensure equipotential connections to ground cables (according to the onsite conditions).

### 5.5.2 Connection Procedure

- step 1 Prepare the cable and OT/DT terminal, refer to "[Crimp OT/DT terminal](#)".
- step 2 Remove the screw on the grounding terminal and fasten the cable with a screwdriver.

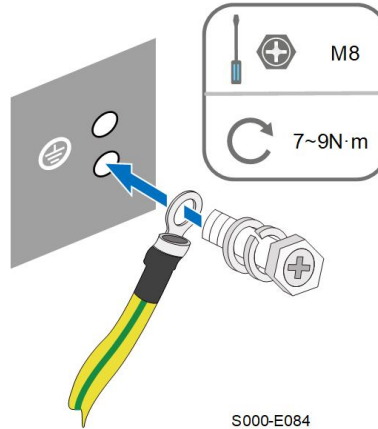

- step 3 Apply paint to the grounding terminal to ensure corrosion resistance.



The grounding screws have been anchored to the side of the inverter before delivery, and do not need to be prepared.

There are two grounding terminals. Use one of them to ground the inverter.

-- End

## 5.6 AC Cable Connection

### 5.6.1 AC Side Requirements



Only with the permission of the local grid department, the inverter can be connected to the grid.

Before connecting the inverter to the grid, ensure the grid voltage and frequency comply with requirements, for which, refer to "[Technical Data](#)". Otherwise, contact the electric power company for help.

## AC Circuit Breaker

### WARNING

**Over-current protection devices, such as AC circuit breakers and fuses, must be installed on the AC side of the inverter and the grid side to ensure safe disconnection between the inverter and the grid.**

- **Do not connect any local load between the inverter and the AC circuit breaker except for the tracking axis.**
- **Multiple inverters cannot share one AC circuit breaker.**

table 5-4 Recommended Specifications of AC Circuit Breaker

Inverter Model	Recommended Rated Voltage	Recommended Rated Current
SG285/320/333/ 350HX	800 V	400 A

### Multiple Inverters in Parallel Connection

When multiple inverters are connected to the grid in parallel, ensure that the maximum number of inverters connected in parallel to a single winding of the box-type substation is 15. Otherwise, please contact SUNGROW for technical scheme.

### MV Transformer

The MV transformer used together with the inverter should meet the following requirements:

- A distribution transformer can be used if it is designed for the typical cyclical loads of a PV system (there is load in the day and no load at night).
- A liquid-immersed type transformer or a dry type transformer can be used, and the shield winding is not a requisite.
- The line-to-line voltage on the LV side of the transformer should endure the output voltage of inverter. When the transformer is connected to the IT grid, to-ground withstanding voltage of the LV winding of the transformer, the LV side AC cables, and the LV side secondary equipment (including the relay protection device, detection & measuring device, and other related auxiliary devices) should not be lower than 1,500V.
- The line-to-line voltage on the HV side of the transformer should comply with the local power grid voltage.
- A transformer with a tap changer on the HV side is recommended in order to keep the voltage consistent with the grid voltage.
- At an ambient temperature of 30°C, the transformer can run in 1.1 times of load for a long time.
- A transformer with a rated capacity of 3200kVA and a short-circuit impedance equal to 7% (permissible tolerance:  $\pm 10\%$ ), or the one with a rated capacity of 4480kVA and a short-circuit impedance equal to 8% (permissible tolerance:  $\pm 10\%$ ) is recommended.
- The voltage drop of system cable is no more than 3%.

- The DC component that the transformer can withstand is 1% of the fundamental current at rated power.
- For thermal rating, the load curve of the transformer and environment conditions should be taken into account.
- The apparent power of the inverter should never exceed the power of the transformer. The maximum AC current of all inverters connected in parallel must be taken into account. If more than 15 inverters are connected to the grid, contact SUNGROW.
- The transformer must be protected against overloading and short circuit.
- The transformer is an important part of grid-connected PV generation system. The fault tolerance capacity of the transformer should be taken into account at all times. The fault include: system short circuit, grounding fault, voltage drop, etc.
- Take ambient temperature, relative humidity, altitude, air quality, and other environmental conditions into account when selecting and installing the transformer.
- The overall technical requirements of the box-type LV cabinet are as follows:
  - The breaking capacity of the branch molded case circuit breaker (MCCB) and air circuit breaker (ACB) of the box-type LV cabinet should be greater than the short circuit current at the LV side of the transformer. For example, the LV side short-circuit current of a boost transformer with a rated capacity of 3200 kVA and a short-circuit resistance of 7% can be calculated in the following way:  $I = 3200 * 1.1 / 0.8 / 1.732 / 0.07 = 36.29 \text{ kA}$ . Thus the MCCB Icu of the LV cabinet branch circuit should be no less than 36.29 kA at 880Vac. The LV side short-circuit current of a boost transformer with a rated capacity of 4480kVA and a short-circuit impedance of 8% can be calculated in the following way:  $I = 4480 * 1.1 / 0.8 / 1.732 / 0.08 = 44.46 \text{ kA}$ . Thus the MCCB Icu of the LV cabinet branch circuit should be no less than 44.46kA at 880Vac.
  - The temperature and altitude derating should be taken into account when a circuit breaker is working, and a LV cabinet temperature rise test report is required.
  - When designing a LV cabinet, must pay attention to the impact of the diffused MCCB electric arc on the cabinet and other branch circuit MCCBs, thus the interior of the cabinet needs to be insulated. A third-party test report of the circuit-breaking performance of the whole machine in an event of a short-circuit on the LV side is also required. It is recommended to adopt graduated protection to ensure that in an event of a single short-circuit fault on the LV side of the box, the corresponding branch MCCB trips normally while the general ACB does not trip.
  - When PLC communication is adopted, the box-type LV power distribution room needs to be equipped with a fuse switch disconnecter or a circuit breaker. The recommended specification of the cable connecting to the EMU200 is 4 mm<sup>2</sup> - 10 mm<sup>2</sup>, the cable voltage specification is 1.8 / 3 kV, and the cable distance from the EMU200 to the box's LV bus should be no more than 10 m.
- When Anti-PID is enabled, the AC output common mode voltage of the inverter is 906V, and the following requirements should be met:
  - The LV side winding of the transformer, AC cables, and secondary devices (including protective relay, detection and measurement instruments, and related auxiliary devices) must withstand the voltage to ground of at least 906 V.

- If the LV side winding is in Y shape, neutral point grounding is prohibited.
- Surge protective devices (SPD) for the AC combiner box and on the LV side of the transformer are recommended to be connected in the "3+1" manner, as shown in the figure below. The Min. continuous operating voltages of M1 - M4 are 680 Vac.

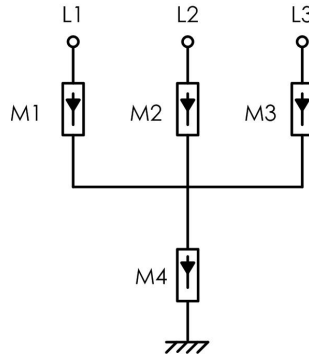

- The string serial communication box EMU200 requires an external power supply of 220 Vac, so a power supply port and an input port (including switches) should be reserved in the LV power distribution room of the boost transformer.

### 5.6.2 Requirements for OT/DT Terminal

OT/DT terminals (not included in the delivery scope) are required for fixing AC cables to the terminal block. Purchase the OT/DT terminals according to the following requirements.

#### OT/DT Terminals of Phase Wire (One Wire per Phase with Multi-core Cable)

- Specification: M12

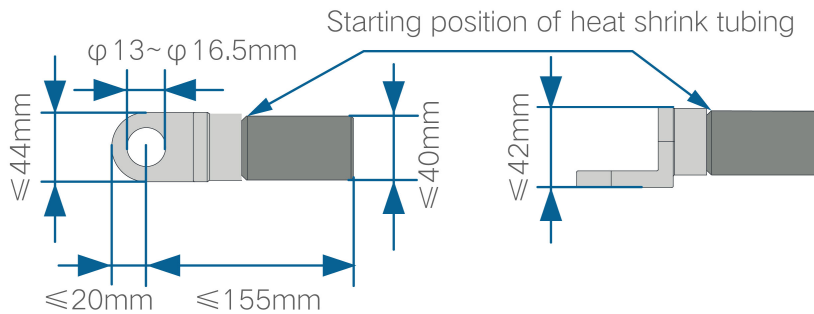

S325-E032

#### OT/DT Terminals of Phase Wire (Two Wires per Phase with Multi-core Cable)

- Specification: M12



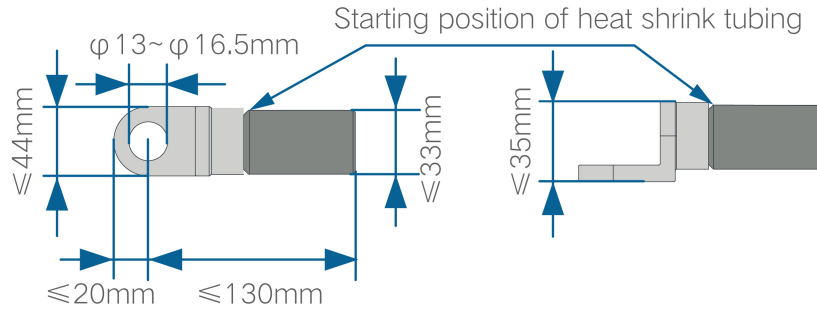

S325-E033

### OT/DT Terminal of PE Wire

- Specification: M12

## 5.6.3 Connection Procedure of One Wire per Phase with Multi-core Cable



This section introduces the connection steps with four-core cable as an example, and the wiring method for three-core cable is the same.

step 1 Disconnect the AC-side circuit breaker and prevent it from inadvertent reconnection.

step 2 Loosen the two screws on the front cover of the junction box with the hexagon socket wrench provided. Open the junction box. During the wiring process, the limit rod attached to the cover keeps the junction box open.

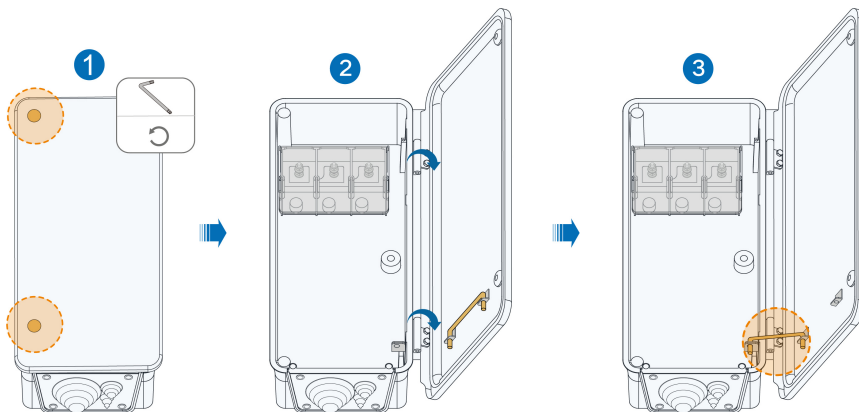

S319-E004



The screws on the front cover of the junction box are captive screws, which will remain on the front cover when the cover is open to avoid screw loss.

step 3 Loosen the screws on the bottom sealing plate with the hexagon socket wrench provided and remove the bottom sealing plate.

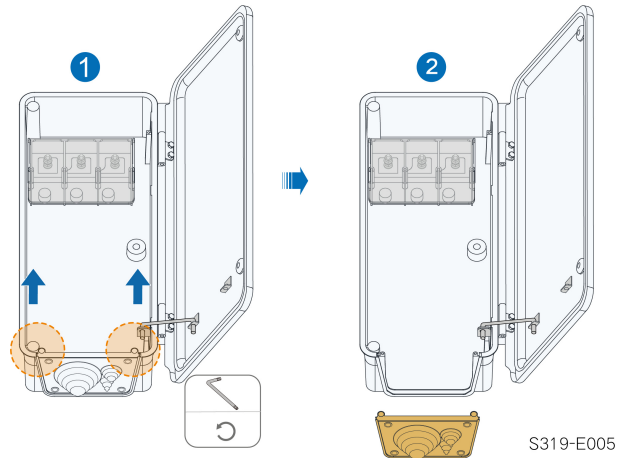

The screws on the sealing plate are captive screws, which will remain on the sealing plate when the sealing plate is removed to avoid screw loss.

step 4 Cut off excess sealing ring according to the outer diameter of the cable.

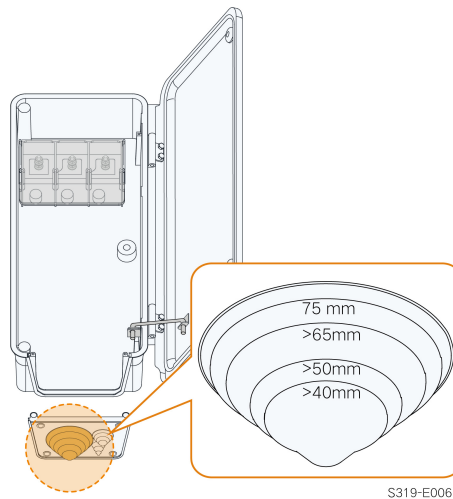

step 5 Lead the cable with the protective layer removed through the sealing ring and fix the screws on the bottom sealing plate.

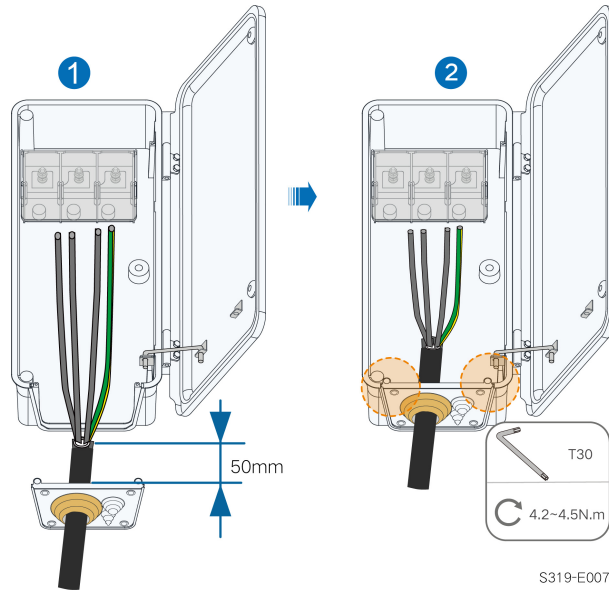

step 6 Open the protection cover.

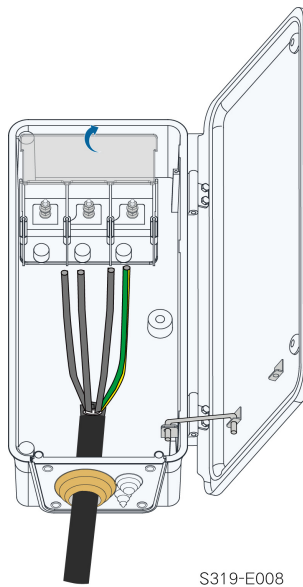

step 7 Fix cables with crimped OT/DT terminals to corresponding terminals. Please fasten AC terminals referring to the torque specified on the label inside the AC box.

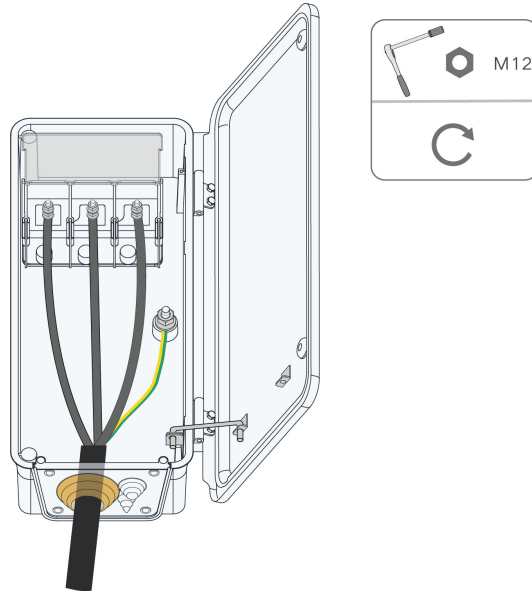

Ensure that the depth  $L$  of the socket used is not less than 28 mm.

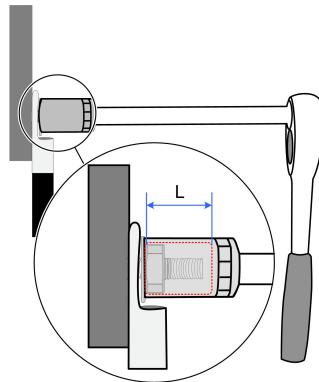

step 8 Close the protection cover.

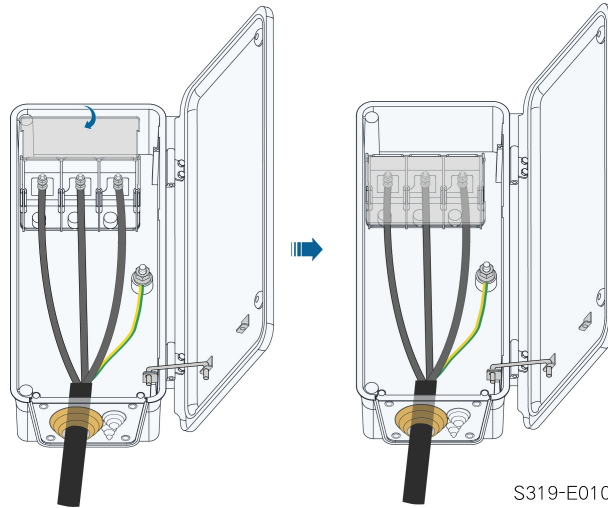

step 9 Remove the limit rod and place it in place. Close the junction box and tighten the two screws on its front cover with the hexagon socket wrench provided.

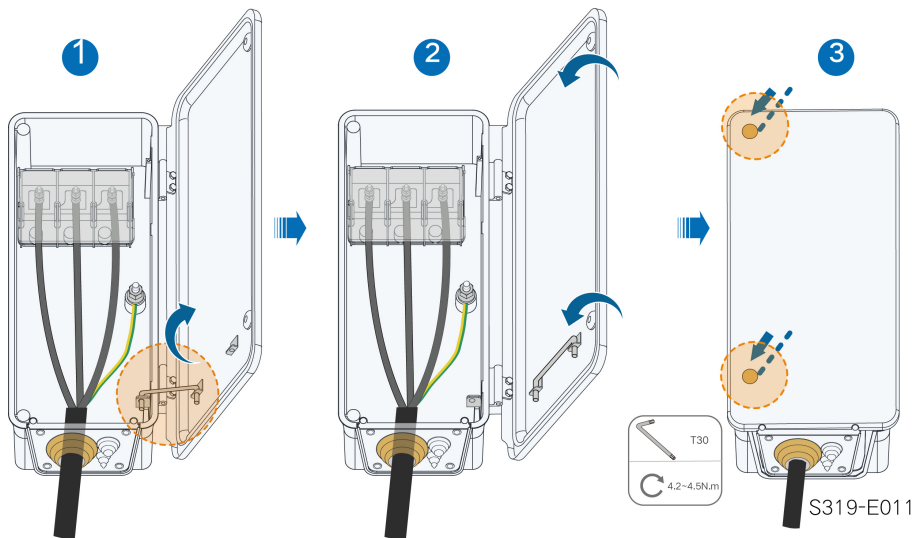

-- End

When a separate single-core cable is used as the PE cable, lead it into the junction box through the standby grounding terminal.

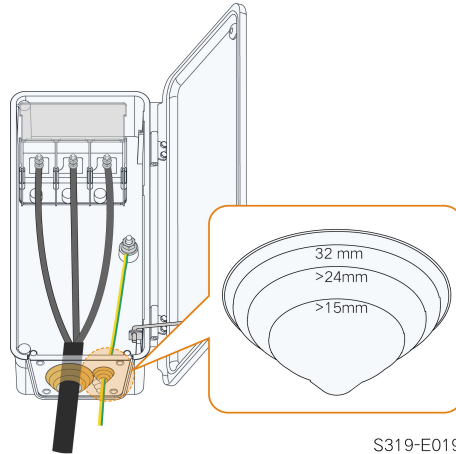

### 5.6.4 Connection Procedure of Two Wires per Phase with Multi-core Cable

- step 1 Disconnect the AC-side circuit breaker and prevent it from inadvertent reconnection.
- step 2 Loosen the two screws on the front cover of the junction box with the hexagon socket wrench provided. Open the junction box. During the wiring process, the limit rod attached to the cover keeps the junction box open.

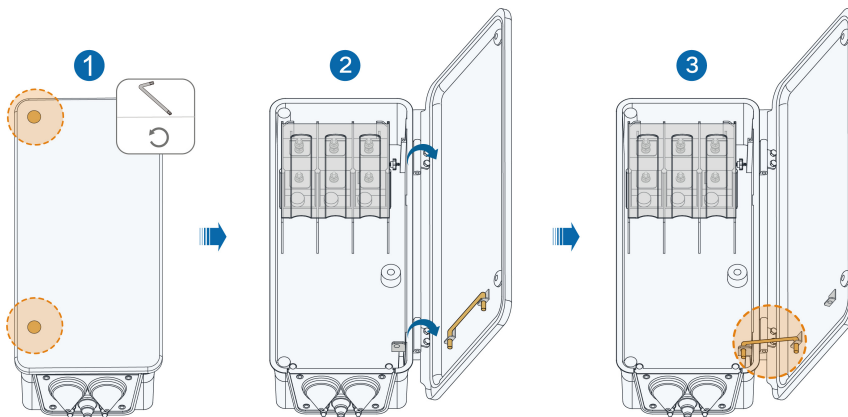

The screws on the front cover of the junction box are captive screws, which will remain on the front cover when the cover is open to avoid screw loss.

- step 3 Loosen the screws on the bottom sealing plate with the hexagon socket wrench provided and remove the bottom sealing plate.

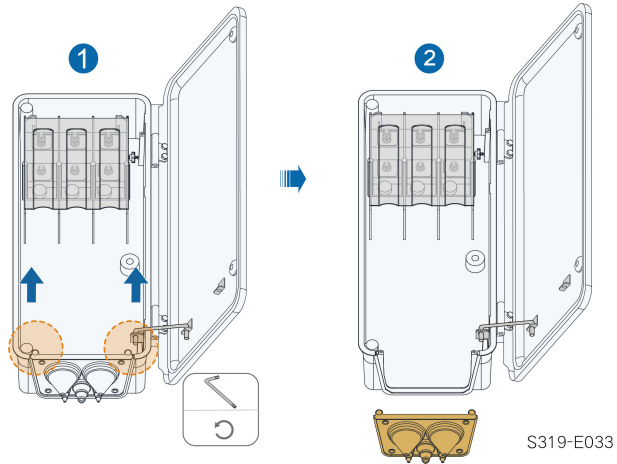

The screws on the sealing plate are captive screws, which will remain on the sealing plate when the sealing plate is removed to avoid screw loss.

step 4 Cut off excess sealing ring according to the outer diameter of the cable.

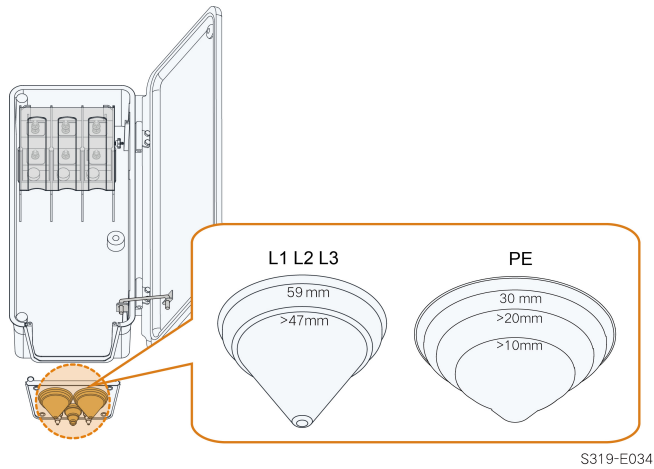

step 5 Lead the cable with the protective layer removed through the sealing ring and fix the screws on the bottom sealing plate.

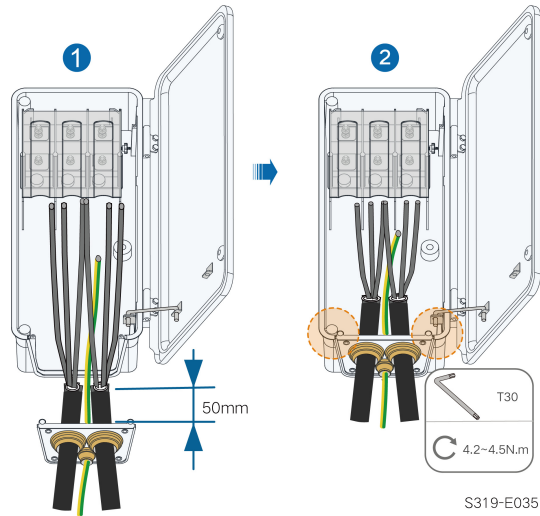

step 6 Open the protection cover.

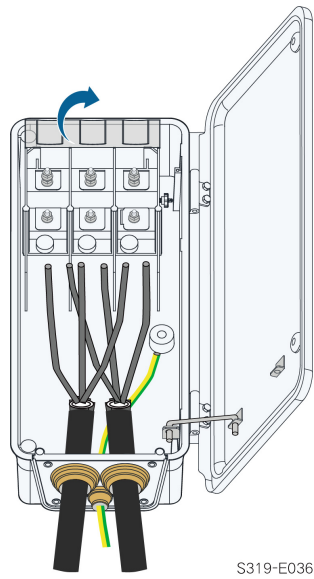

step 7 Fix cables with crimped OT/DT terminals to corresponding terminals. Please fasten AC terminals referring to the torque specified on the label inside the AC box.



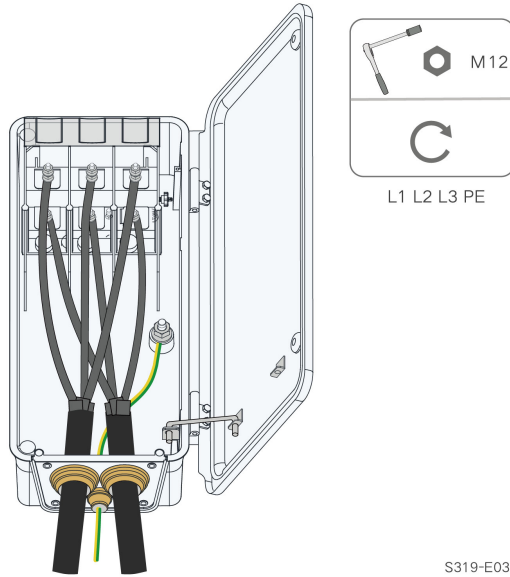

Ensure that the depth L of the socket used is not less than 28 mm.

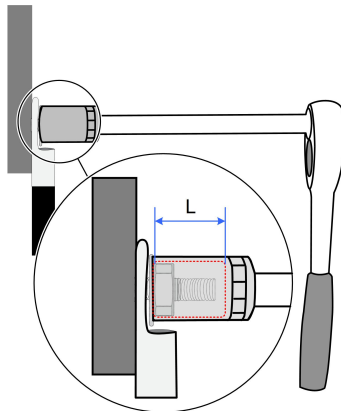

step 8 Close the protection cover after fixing all cables to corresponding terminals.

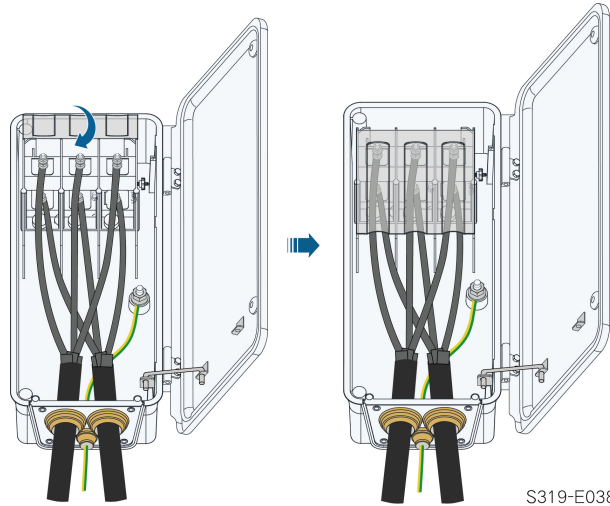

step 9 Remove the limit rod and place it in place. Close the junction block and tighten the two screws on its front cover with the hexagon socket wrench provided.

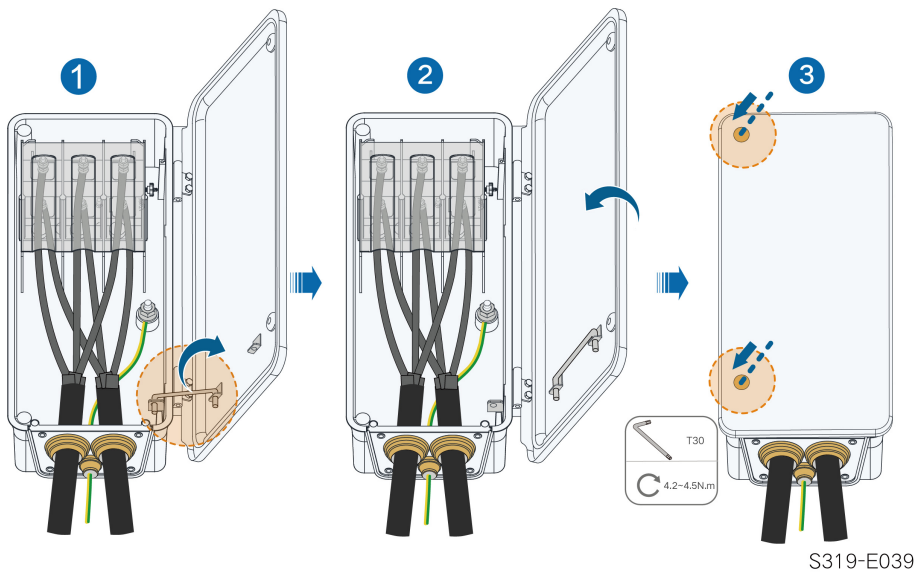

-- End

## 5.7 DC Cable Connection

**⚠ DANGER**

The PV string will generate lethal high voltage when exposed to sunlight.

- Respect all safety instructions listed in relevant documents about PV strings.

**⚠ WARNING**

- **Make sure the PV array is well insulated to ground before connecting it to the inverter.**
- **Make sure the maximum DC voltage and the maximum short circuit current of any string never exceed inverter permitted values specified in "Technical Data".**
- **Check the positive and negative polarity of the PV strings, and connect the PV connectors to corresponding terminals only after ensuring polarity correctness.**
- **During the installation and operation of the inverter, please ensure that the positive or negative electrodes of PV strings do not short-circuit to the ground. Otherwise, an AC or DC short-circuit may occur, resulting in equipment damage. The damage caused by this is not covered by the warranty.**
- **Electric arc or contactor over-temperature may occur if the PV connectors are not firmly in place, and SUNGROW shall not be held liable for any damage caused.**
- **If the DC input cables are reversely connected or the positive and negative terminals of different MPPT are shorted to ground at the same time, while the DC switch is in the "ON" position, do not operate immediately. Otherwise, the inverter may be damaged. Please turn the DC switch to "OFF" and remove the DC connector to adjust the polarity of the strings when the string current is lower than 0.5 A.**
- **Use the DC connectors supplied with the product for DC cable connection. Using incompatible DC connectors may result in serious consequences, and the device damage is not covered under warranty.**
- **Inverters do not support full parallel connection of strings (Full parallel connection refers to a connection method in that strings are connected in parallel and then connected to the inverter separately).**
- **Do not connect one PV string to multiple inverters. Otherwise, the inverters may be damaged.**

**NOTICE**

**The following requirements about PV string connection must be met. Otherwise, it may cause irreversible damage to the inverter, which is not covered by the warranty.**

- **Mixed use of PV modules of different brands or models in one MPPT circuit, or PV modules of different orientation or inclination in a string may not damage inverter, but will cause system bad performance!**

### 5.7.1 PV Input Configuration

- As shown in the figure below, the inverter is provided with multiple PV inputs, each PV input is designed with an MPP tracker.

- Each PV input operates independently and has its own MPPT. In this way, string structures of each PV input may differ from each other, including number of PV modules in each string, angle of tilt, and installation orientation.
- Each PV input includes two PV strings. In order to fully utilize the input power of PV panels, the PV strings of each PV input should have the same structure, including the same type, the same number, the same tilt, and the same orientation.

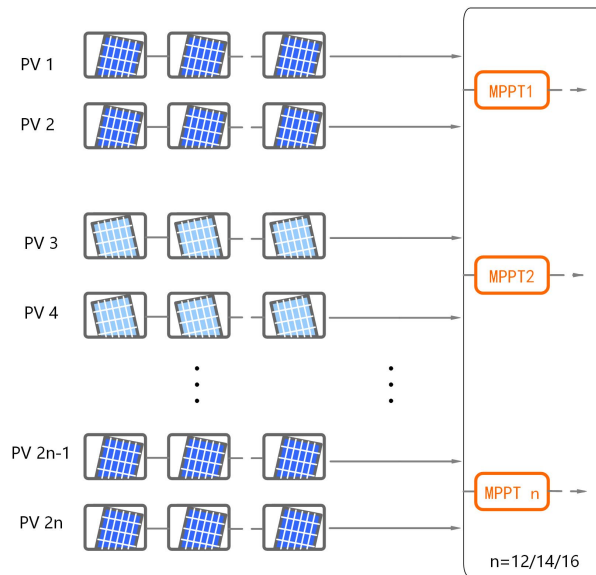

figure 5-6 PV Input Configuration

Prior to connecting the inverter to PV inputs, the specifications in the following table should be met:

Open-circuit Voltage Limit	Max. Current for Input Connector
1500 V	30 A (SG285HX / SG333HX / SG350HX)
	40 A (SG320HX)

### 5.7.2 Assembling PV Connectors

#### **⚠ DANGER**

**High voltage may be present in the inverter!**

- Ensure all cables are voltage-free before performing electrical operations.
- Do not connect the AC circuit breaker before finishing electrical connection.

**NOTICE**

Please use the DC terminal within the scope of delivery or purchase the PV connector according to the recommended model below. Equipment damage caused by the use of unmatched terminals is not covered by the warranty.

- If the cross-sectional area of the DC cable is  $4/6\text{mm}^2$ , use the PV connector within the scope of delivery. The recommended model of the female cable connector is PV-KST4-EVO 2 / 6I-UR (Stäubli), and the recommended male cable connector is PV-KBT4-EVO 2 / 6I-UR (Stäubli).
- If the cross-sectional area of the DC cable is  $10\text{mm}^2$ , users need to prepare the PV connector by themselves or order it from SUNGROW. The recommended model of the female cable connector is PV-KBT4-EVO 2 / 10II-UR (Stäubli), and the recommended male cable connector is PV-KST4-EVO 2 / 10II-UR (Stäubli).

step 1 Strip the insulation from each DC cable by 8 mm ~ 10 mm.

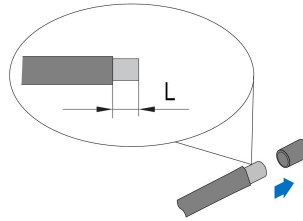

step 2 Assemble the cable ends with the crimping pliers.

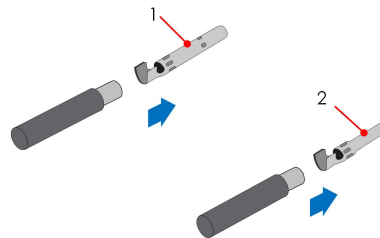

1: Positive crimp contact

2 : Negative crimp contact

step 3 Lead the cable through the cable gland, and insert the crimp contact into the insulator until it snaps into place. Gently pull the cable backward to ensure firm connection.

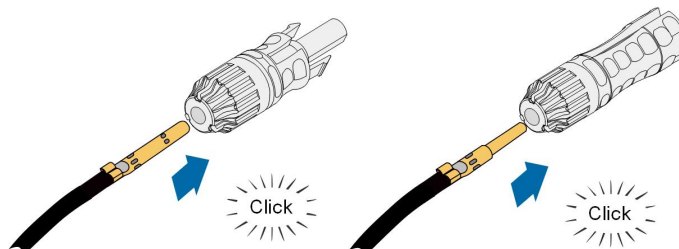

step 4 Tighten the cable gland and the insulator.

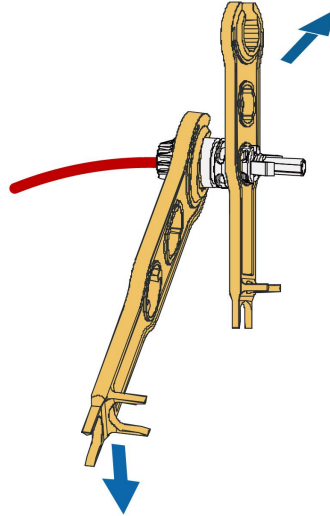

step 5 Check for polarity correctness.

#### NOTICE

If the PV polarity is reversed, the inverter will be in a fault or alarm state and will not operate normally.

-- End

### 5.7.3 Installing PV Connector

step 1 Ensure that the DC switch is in "OFF" position. Otherwise, manually turn it to "OFF".

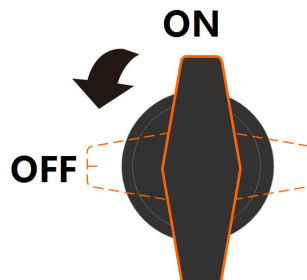

step 2 Check the cable connection of the PV string for polarity correctness and ensure that the open circuit voltage in any case does not exceed the inverter input limit of 1,500 V.

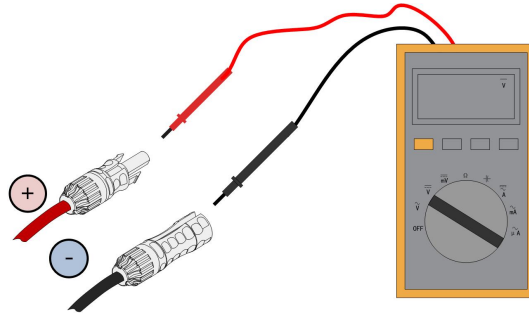
**NOTICE**

The multimeter must have a DC voltage range of at least 1500 V. If the voltage is a negative value, the DC input polarity is incorrect. Please correct the DC input polarity. If the voltage is greater than 1500 V, too many PV modules are configured to the same string. Please remove some PV modules.

step 3 Connect the PV connectors to corresponding terminals until there is an audible click.

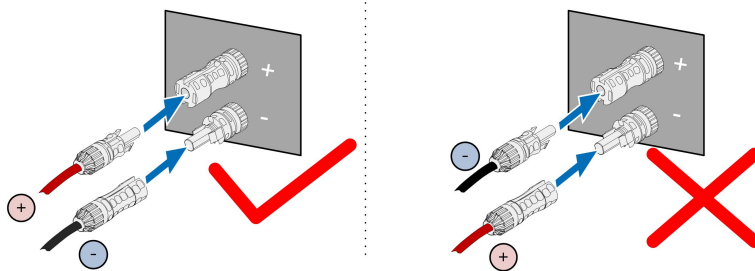

step 4 Follow the foregoing steps to connect PV connectors of other PV strings.

step 5 Seal any unused PV terminal with a terminal cap.

-- End

## 5.8 Wiring of Tracking System Power Cable (Optional)

step 1 Refer to step 1 to step 2 described in "5.6.3 Connection Procedure of One Wire per Phase with Multi-core Cable".

step 2 Cut off excess sealing ring according to the outer diameter of the cable.

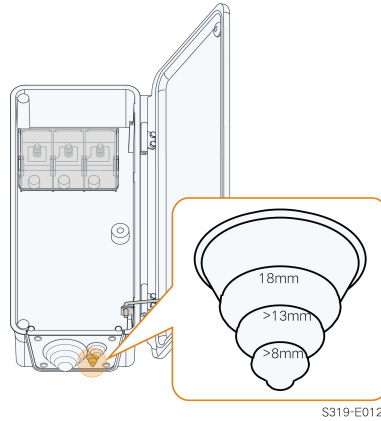

step 3 Lead the cable with the protective layer removed through the sealing ring. Retain 50 mm of cable with the protective layer in the AC junction box.

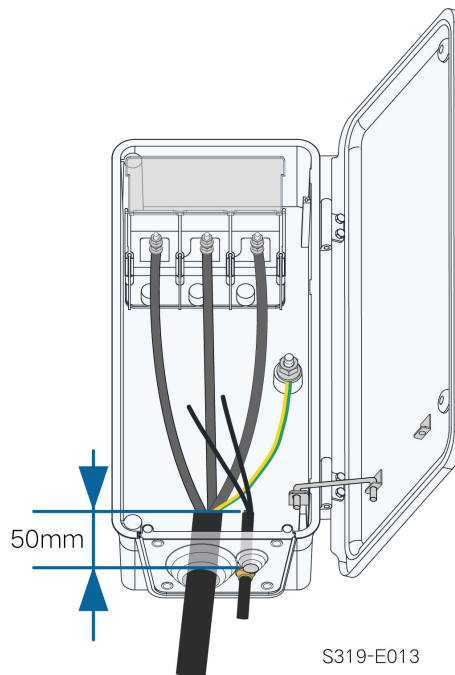

step 4 Stack the OT terminals on the OT/DT terminals of the AC cables, and fix the cables to corresponding terminals.



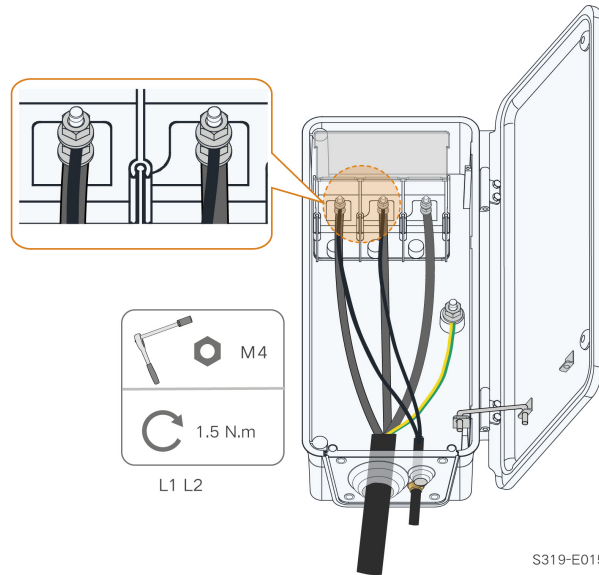

**i** The tracking power cable can be installed in any two phases among L1/L2/L3.

step 5 Close the protection cover. Close the junction box and tighten the two screws on its front cover with supplied Allen wrench.

-- End

**i** Protection devices required between the inverter and the tracking system control box: disconnecter switch ( $\geq 800$  Vac) + fuse (16A, gM).  
Length of the cable connecting the internal wiring terminal of the inverter and the fuse should be less than 2.5 m.

## 5.9 RS485 Connection(COM1)

### 5.9.1 Interface Description

The inverter communication terminal COM1 is located at the bottom of the inverter, as shown in the figure below.

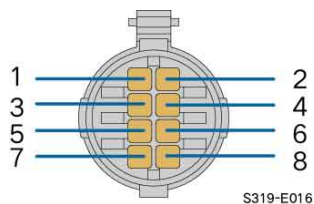

table 5-5 COM1 Terminal Definition

Port	PIN	Definition	Description
RS485_1	1	RS485A IN, RS485 differential signal+	Used for cascading inverters or connecting to devices such as the Data Logger.
	2	RS485A IN, RS485 differential signal+	
	3	RS485B OUT, RS485 differential signal-	
	4	RS485B OUT, RS485 differential signal-	
PE	5	PE, shielding ground	—
	6	PE, shielding ground	
RS485_2	7	RS485A, RS485 differential signal+	Used for connecting to communication devices of the tracking system.
	8	RS485B, RS485 differential signal-	

## 5.9.2 RS485 Communication System

### Single-inverter Communication System

In case of a single inverter, communication cable connection requires only one RS485 cable.

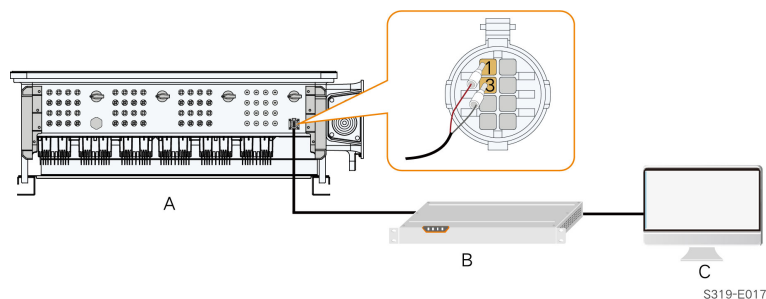

(A) Inverter

(B) Data Logger

(C) PC

### Multi-inverter Communication System

In case of multiple inverters, all the inverters can be connected via RS485 cables in the daisy chain manner. The communication cable of the tracking system can be connected to the port RS485\_2 of any inverter in the daisy chain.

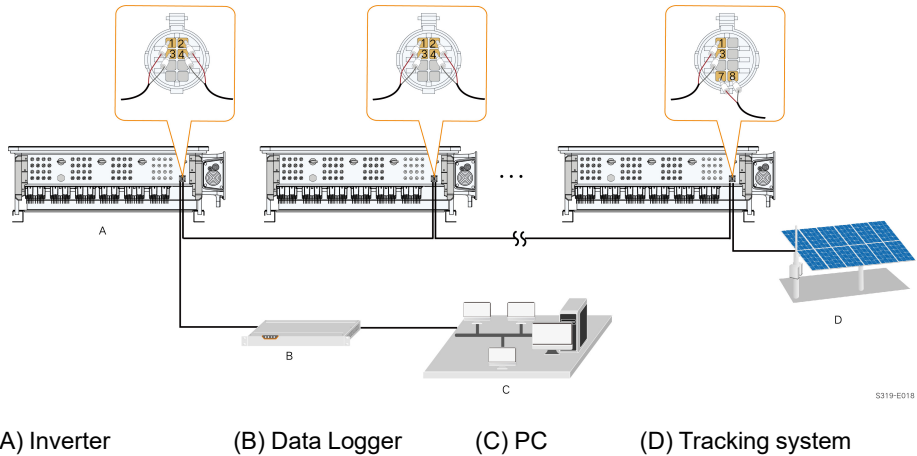

The length of the RS485 cable should be no longer than 1,000 m.



If multiple inverters are connected to the data logger, the number of permissible daisy chains and the number of devices allowed to be connected should meet the requirements (refer to the user manual of the data logger).

### 5.9.3 Connection Procedure

step 1 Unscrew the swivel nut from the communication terminal and take out the seal.

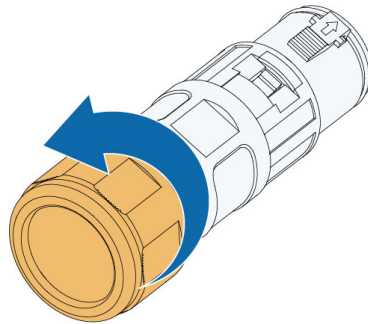

step 2 Press the snap on both sides of the connector to separate the cable gland and the terminal block.

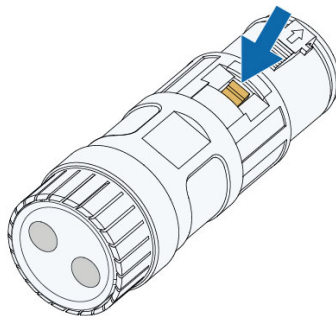

step 3 Select a seal according to the cable outer diameter. Lead the cable through the swivel nut, seal and the cable gland.

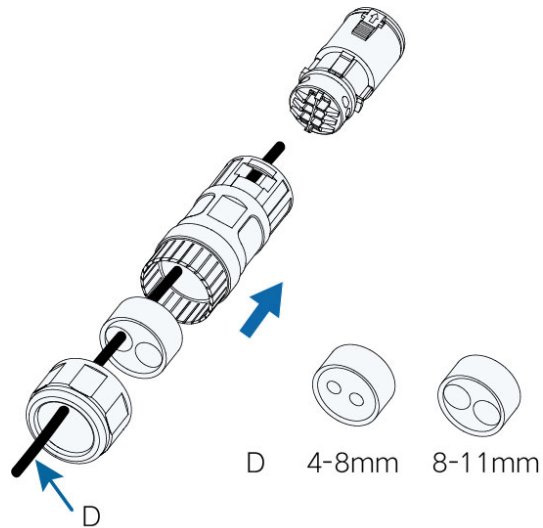

step 4 Strip the protective layer and the insulation layer of the cable to proper length.

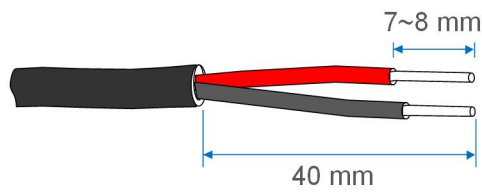

step 5 Secure the wires to corresponding terminals.

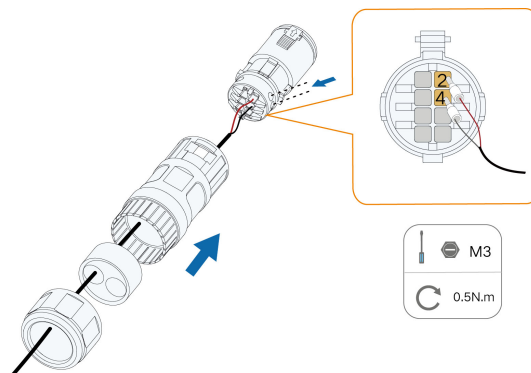

step 6 Pull cables outwards to confirm whether they are fastened firmly, then tighten the swivel nut with appropriate torque.

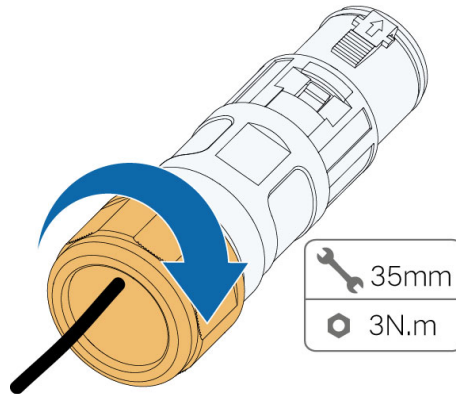

step 7 Remove the waterproof lid from the communication terminal COM1.

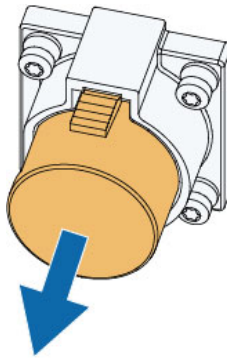

step 8 Insert the connector into the communication terminal.

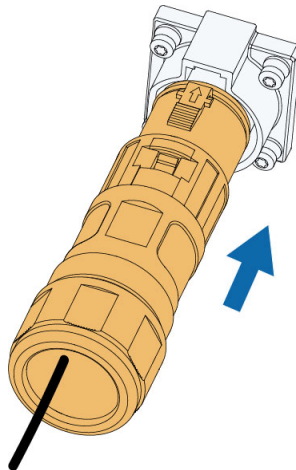

step 9 Seal the vacant cable hole with a waterproof plug.

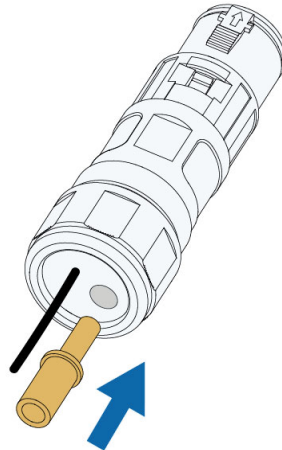

-- End

## 5.10 Dry Contact Connection(COM2)



Communication terminal COM2 is optional, subject to actual product received.

### 5.10.1 Interface Description

The inverter communication terminal COM2 is located at the bottom of the inverter, as shown in the figure below.

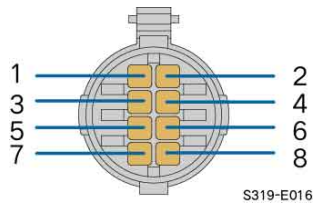

table 5-6 COM2 Terminal Definition

Port	PIN	Definition	Description
/	1	/	
/	2	/	
DI	3	DI	Emergency stop dry contact
	4	PGND	
D0	5	COM	Fault output dry contact
	6	NC	
	7	NO	
/	8	/	

### 5.10.2 Dry Contact Function

**DI terminal (emergency stop dry contact):** the dry contact can be configured to be an emergency stop contact.

When the DI contact and PGND contact are shorted by external controlled switch (the external switch can be configured as normally open contact or normally closed contact), the inverter will immediately stop.



The dry contacts only support passive switch signal input.

The following figure shows the typical application of emergency stop dry contact.

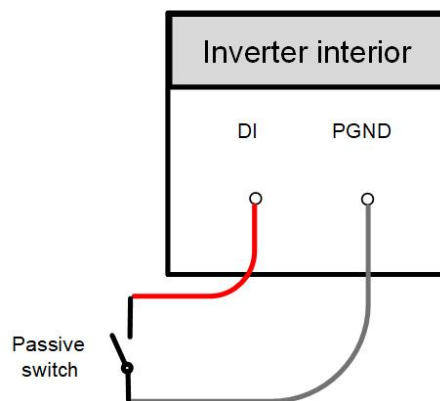

figure 5-7 Local Stop Contact

When wiring DI dry contacts, ensure that the maximum wiring distance meet the requirements in "9.2 Wiring Distance of DI Dry Contact".

**DO terminal (fault output dry contact):** the relay can be set to fault alarm output, and user can configure it to be a normally open contact (COM & NO) or a normally closed contact (COM & NC).

The relay is initially at the NC contact, and it will trip to another contact when a fault occurs. Use LED indicators or other equipment to indicate whether the inverter is in the faulty state.

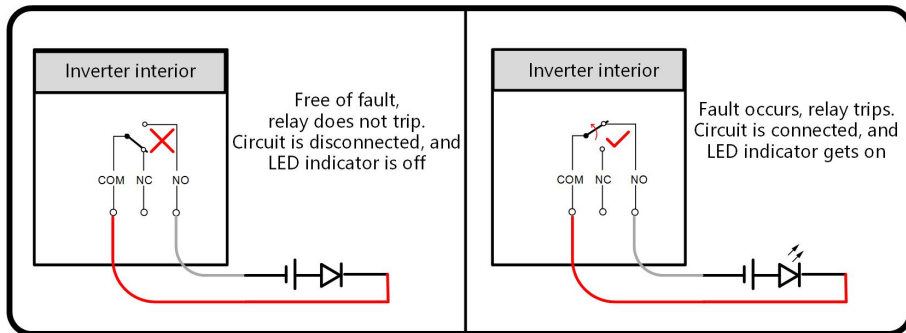

figure 5-8 Normal open contact

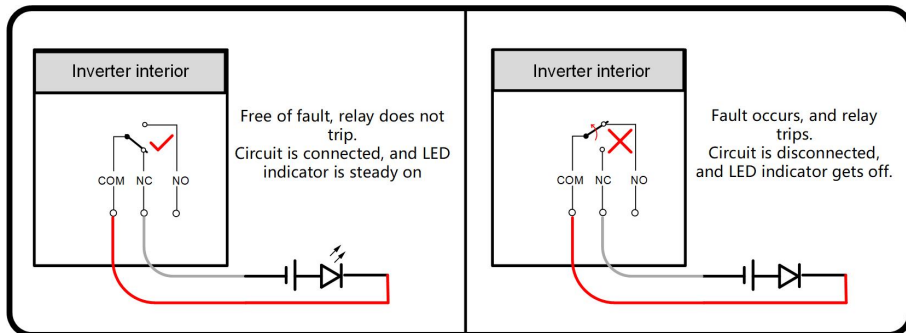

figure 5-9 Normally Closed Contact

Devices connected to the relay should comply with related requirements:

AC-Side Requirements	DC-Side Requirements
Max. voltage: 230 Vac	Max. voltage: 30Vdc
Max. current: 3A	Max. current: 3A

### 5.10.3 Connection Procedure

step 1 Unscrew the swivel nut from the communication terminal and take out the seal.

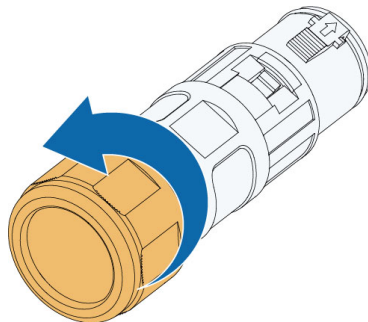

step 2 Press the snap on both sides of the connector to separate the cable gland and the terminal block.



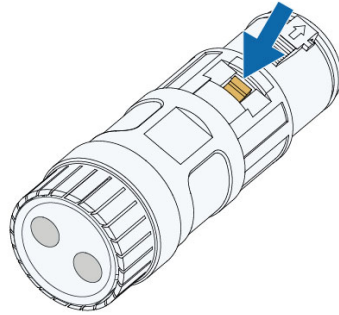

step 3 Select a seal according to the cable outer diameter. Lead the cable through the swivel nut, seal and the cable gland.

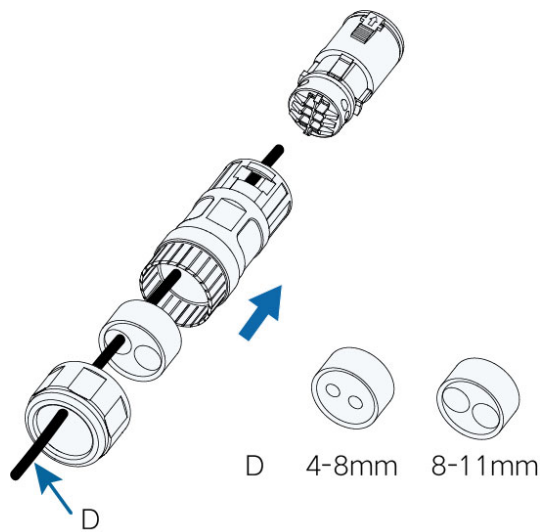

step 4 Strip the protective layer and the insulation layer of the cable to proper length.

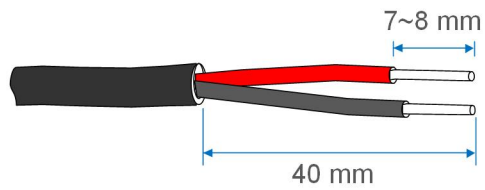

step 5 Secure the wires to corresponding terminals.

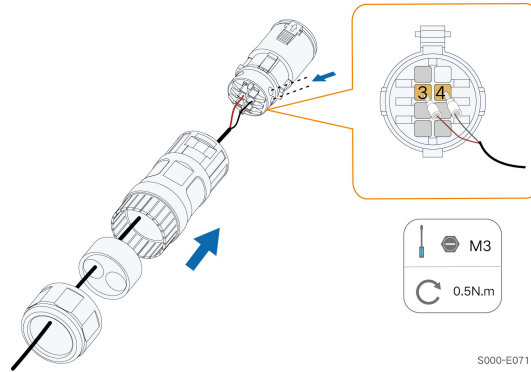

step 6 Pull cables outwards to confirm whether they are fastened firmly, then tighten the swivel nut with appropriate torque.

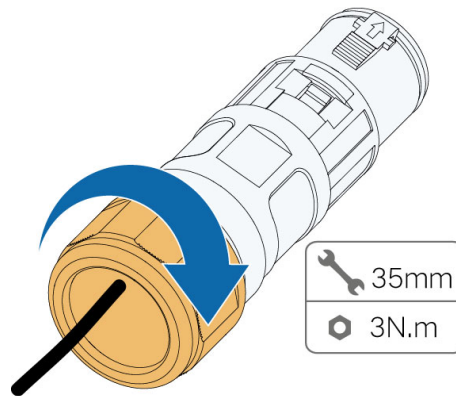

step 7 Remove the waterproof lid from the communication terminal COM2.

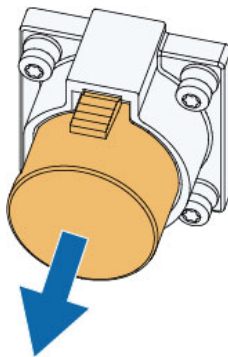

step 8 Insert the connector into the communication terminal.

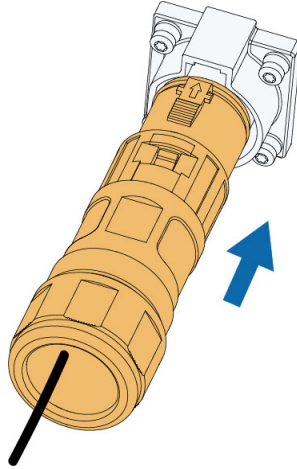

step 9 Seal the vacant cable hole with a waterproof plug.

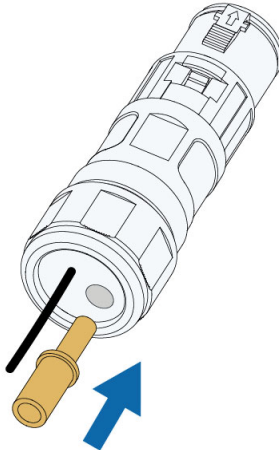

-- End

## 5.11 PLC Communication Connection

With a PLC communication module built inside, the inverter can communicate with the Data Logger provided by SUNGROW. For specific wiring method, refer to the user manual for the data logger.

The maximum PLC communication distance from the box-type substation to the inverter is:

- If there is one cable per phase, with single-core cable, the maximum communication distance is 800 m. Bind three-phase cables with cable ties every 1 m.

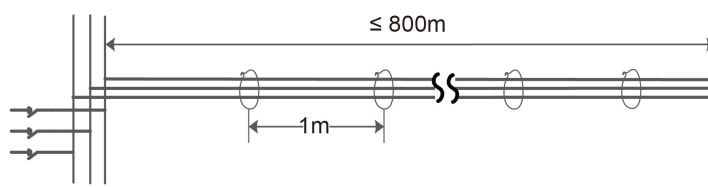

- If there are two cables per phase, with single-core cable, the maximum communication distance is 800 m. Bind three-phase cables with cable ties every 1 m. The length of the two AC cables should be the same. If not, the length difference must be smaller than 5 m.

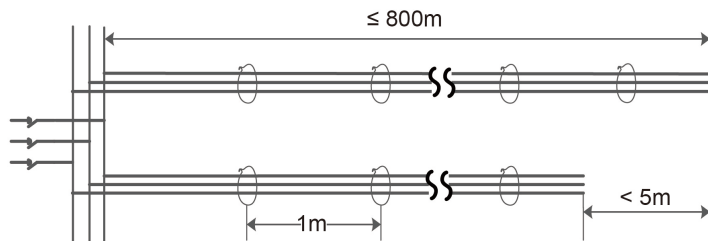

- If there is one wire per phase, with multi-core cable, the maximum communication distance is 1000 m.

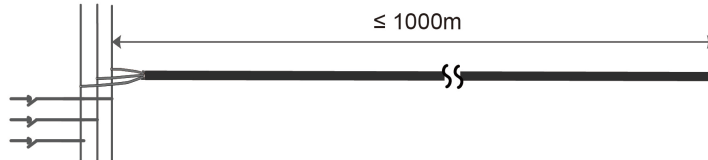

- If there are two wires per phase, with multi-core cable, the maximum communication distance is 1000 m. The length of the two AC cables should be the same. If not, the length difference must be smaller than 5 m.

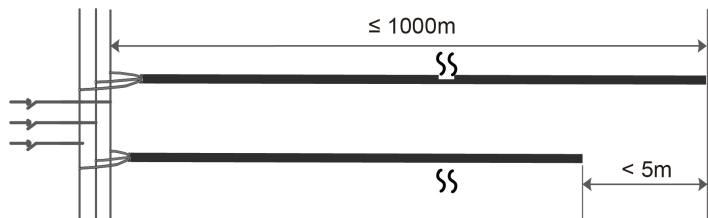



- The Data Logger is an optional device that can be ordered from SUNGROW.
- The Data Logger conducts data communication by directly using the AC output cable of the inverter and thus saves the trouble to lay and maintain the special communication cables. The RS-485 port of the Data Logger supports the transparent transmission of the MODBUS-RTU and is completely compatible with the monitoring devices and software of the original RS-485 communication method.

## 6 Commissioning

### 6.1 Inspection Before Commissioning

Check the following items before starting the inverter:

- All equipment has been reliably installed.
- DC switch(es) and AC circuit breaker are in the "OFF" position.
- The ground cable is properly and reliably connected.
- The AC cable is properly and reliably connected.
- The DC cable is properly and reliably connected.
- The communication cable is properly and reliably connected.
- The vacant terminals are sealed.
- No foreign items, such as tools, are left on the top of the machine or in the junction box (if there is).
- The AC circuit breaker is selected in accordance with the requirements of this manual and local standards.
- All warning signs & labels are intact and legible.

### 6.2 Commissioning Procedure

If all of the items mentioned above meet the requirements, proceed as follows to start up the inverter for the first time.

- step 1 Rotate one DC switch of the inverter to the "ON" position. When the indicator blinks blue slowly, turn the other DC switches to the "ON" position.

#### NOTICE

- **Strictly follow the preceding sequence. Otherwise, the product may be damaged, and the loss caused is not covered by the warranty.**
- **If the DC side is powered up while the AC side is not, the inverter will report a fault named "Grid Power Outage" (the fault information can be viewed on the iSolarCloud App, see "Records" for details). The fault is automatically cleared when the AC circuit breaker between the inverter and the grid is closed.**
- **Before closing the AC circuit breaker between the inverter and the power grid, use a multimeter that is set to the AC gear to ensure that the AC voltage is within the specified range. Otherwise, the inverter may be damaged.**

- step 2 Close the AC circuit breaker between the inverter and the grid.
- step 3 Install the iSolarCloud App, see "[7.2 Installing App](#)" for details.
- step 4 Set initial protection parameters via the iSolarCloud App when the inverter is connected to the grid for the first time (see Step 4 in "[7.3.2 Login Procedure](#)" for details). If the irradiation and grid conditions meet requirements, the inverter normally operates.
- step 5 The home page is automatically displayed when the setting is completed. The indicator is steady blue, and the inverter is in grid-connected operation.

**⚠ WARNING**

**It is strictly forbidden to close the DC switch if the inverter is in grid-connected status. Otherwise, the inverter may be damaged due to the lack of insulation impedance detection, and the loss caused is not covered by the warranty.**

**-- End**

# 7 iSolarCloud App

## 7.1 Brief Introduction

The iSolarCloud App can establish communication connection to the inverter via the Bluetooth, thereby achieving near-end maintenance on the inverter. Users can use the App to view basic information, alarms, and events, set parameters, or download logs, etc.



Screenshots in this manual are based on the Android system V2.1.6 , and the actual interfaces may differ.

## 7.2 Installing App

### Method 1

Download and install the App through the following application stores:

- MyApp (Android, mainland China users)
- Google Play (Android, users other than mainland China ones)
- App Store (iOS)

### Method 2

Scan the following QR code to download and install the App according to the prompt information.



The App icon appears on the home screen after installation.





## 7.3 Login

### 7.3.1 Requirements

The following requirements should be met:

- The AC or DC side of the inverter is powered-on.
- The mobile phone is within 5 meters away from the inverter and there are no obstructions in between.
- The Bluetooth function of the mobile phone is enabled.



The inverter can only pair with one phone at a time through Bluetooth.

### 7.3.2 Login Procedure

- step 1 Open the App to enter the login page, tap **Local Access** at the bottom of the page to go to the next page.
- step 2 Establish the Bluetooth connection by either of the two following ways. If the LED indicator flashes blue, the connection is successfully established.
  - Scan the QR code on the side of the inverter for Bluetooth connection.
  - Tap "Manual connection" and select "Others" at the bottom of the page, the Bluetooth search page will automatically pop up, and select the inverter to be connected according to the SN on the nameplate on the side of the inverter body.

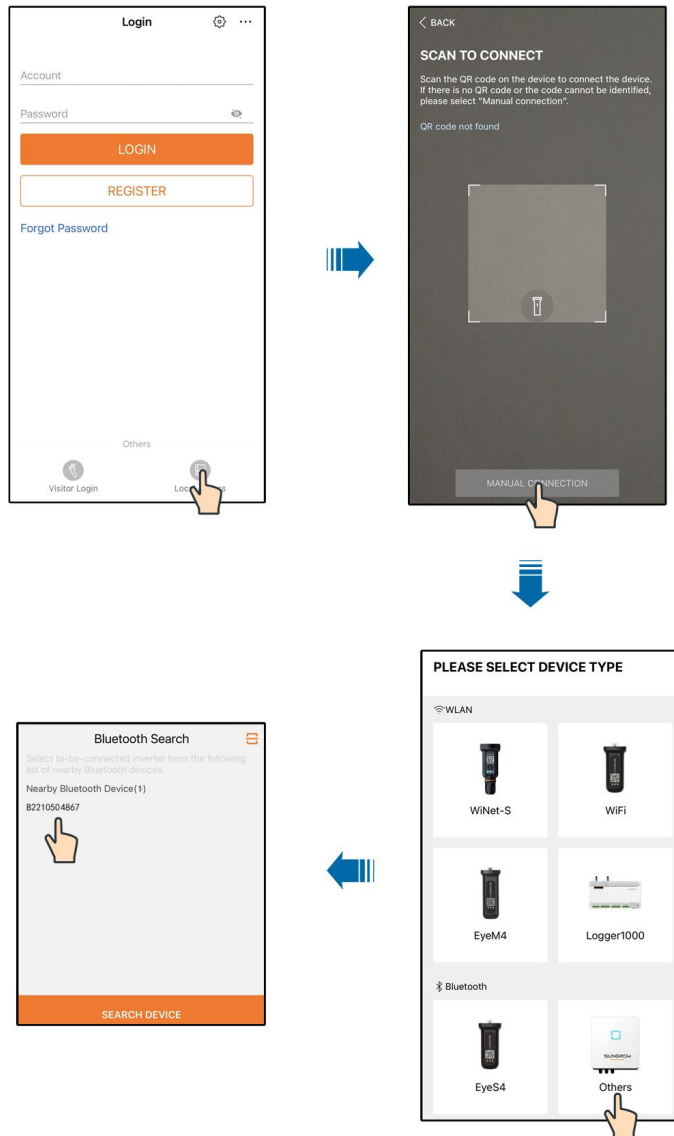

figure 7-1 Bluetooth Connection

step 3 Enter the identity verification interface after the Bluetooth connection is established.

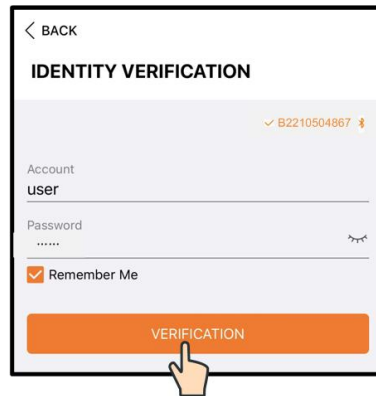

figure 7-2 Login



The Account is "user", and the initial password is "pw1111" or "111111" which should be changed for the consideration of account security.

To set inverter parameters related to grid protection and grid support, contact your distributor to obtain the advanced account and corresponding password. If the distributor is unable to provide the required information, contact SUNGROW.

step 4 If the inverter is not initialized, you will enter the quick setting interface of initializing protection parameter.

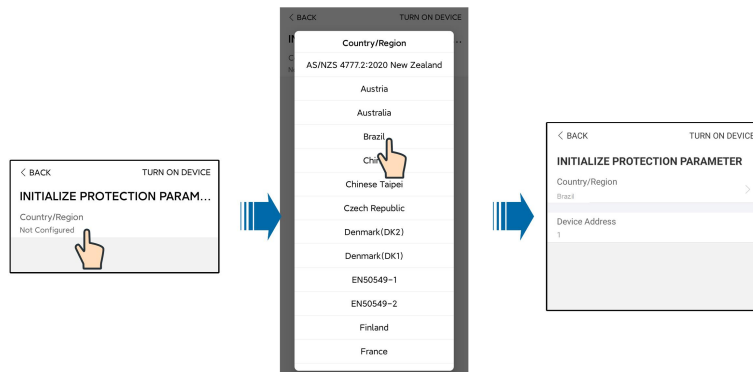

figure 7-3 Initialization Protection Parameter

#### NOTICE

**The Country/Region must be set to the country where the inverter is installed. Otherwise, the inverter may report errors.**

step 5 After finishing the settings, tap **TUNR ON DEVICE** at the upper right corner and the device will be initialized. The App will send start instructions and the device will start and operate.

step 6 If the inverter is initialized, the App automatically turns to its home page.

-- End

## 7.4 Function Overview

The App provides parameter viewing and setting functions, as shown in the following figure.

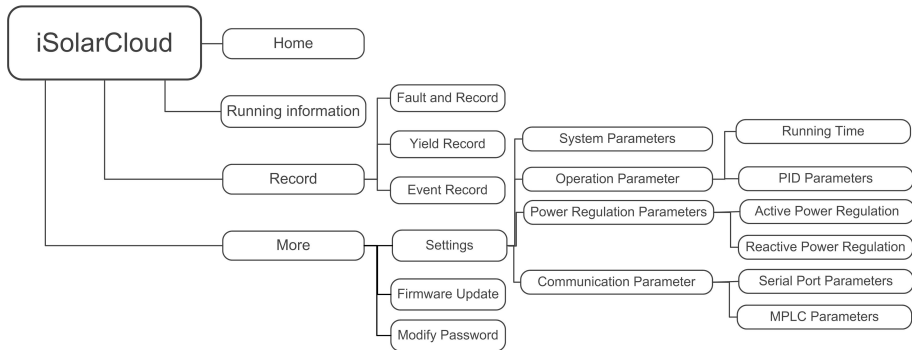

figure 7-4 App Function Tree Map

## 7.5 Home

After login, the home page is as follows:

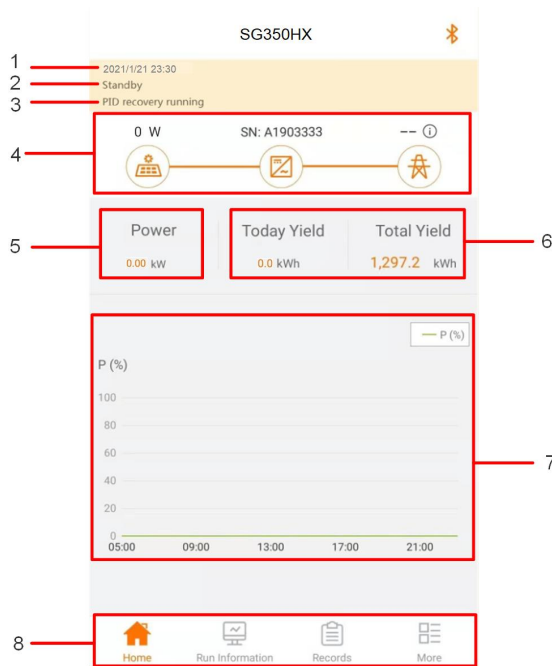

figure 7-5 Home Page

table 7-1 Home Page Description

No.	Designation	Description
1	Date and time	System date and time of the inverter
2	Inverter state	Present operation state of the inverter. For details, refer to " <a href="#">table 7-2 Description of Inverter State</a> ".
3	PID function state	Present state of the PID function. For details, refer to " <a href="#">table 7-3 Description of PID Function State</a> ".
4	Power flow chart	Display the PV power generation power, feed-in power, etc. The line with an arrow indicates energy flow between connected devices, and the arrow pointing indicates energy flow direction.
5	Real-time power	Output power of the inverter
6	Power generation	Today power yield and accumulative power yield of the inverter
7	Power curve	Curve showing change of power between 5 am and 23 pm every day (Each point on the curve represents the percentage of present inverter power to rated power)
8	Navigation bar	Including <b>Home</b> , <b>Run Information</b> , <b>Records</b> , and <b>More</b>

table 7-2 Description of Inverter State

State	Description
Run	After being energized, inverter tracks the PV arrays' maximum power point (MPP) and converts the DC power into AC power. This is the normal operation mode.
Stop	Inverter is stopped.
Press to Shut Down	Inverter will stop operation by tapping "Stop" via app. In this way, inverter internal DSP stops. Restart the inverter via app if needed.
Standby	Inverter enters standby mode when DC side input is insufficient. In this mode inverter will wait within the standby duration.
Initial standby	The inverter is in the initial power-on standby state.
Starting up	The inverter is initializing and synchronizing with the grid.
Warn run	Warning information is detected.
Derating	The inverter derates actively due to environmental factors such as temperature or altitude
Dispatch Running	The inverter runs according to the scheduling instructions received from the monitoring background
Shut down	If a fault occurs, inverter will automatically stop operation, the AC relay acts. The fault information will be displayed on the app. Once the fault is removed in recovery time, inverter will automatically resume running.

table 7-3 Description of PID Function State

State	Description
PID recovery running	The inverters perform PID recovery actively.
PID abnormality	It is detected that the ISO impedance is abnormal or the PID function cannot work normally after the PID function is enabled.

If the inverter is running abnormally, the alarm or fault icon  will be displayed in the lower right corner of the inverter icon in power flow chart. The user can tap this icon to enter the alarm or fault interface to view detailed information and corrective measures.

## 7.6 Run Information

Tap **Run Information** in the navigation bar to enter the corresponding interface. Swipe upward to view details.

The run information includes the PV information, the inverter information, and input and output information.

table 7-4 Run Information

Classification	Parameter Name	Description
PV Information	String n Voltage	The input voltage of String n
	String n Current	The input current of String n
Inverter Information	Total On-grid Running Time	/
	Daily On-grid Running Time	/
	Negative Voltage to Ground	Inverter DC side negative to ground voltage value
	Bus Voltage	Voltage between the positive and negative poles of the DC side of the inverter
	Internal Air Temperature	/
	Array Insulation Resistance	Insulation resistance value of the input side to the protection ground
	Country/Region	/
	Power Limitation Mode	/
	Reactive Power Mode	/
	Input	Total DC Power
MPPT x Voltage		The input voltage of MPPT x
MPPT x Current		The input current of MPPT x
Output	Daily Yield	/
	Monthly Yield	/
	Annual Yield	/
	Total Active Power	Current active power value of the inverter
	Total Reactive Power	Current reactive power value of the inverter
	Total Apparent Power	Current apparent power value of the inverter
	Total Power Factor	Power factor of the AC side of the inverter
	Grid Frequency	Frequency of the AC side of the inverter
	A-B Line Voltage	Line voltage
	B-C Line Voltage	
	C-A Line Voltage	
	Phase A Current	Phase current
	Phase B Current	

Classification	Parameter Name	Description
	Phase C Current	

## 7.7 Records

Tap **Records** on the navigation bar to enter the interface showing event records, as shown in the following figure.

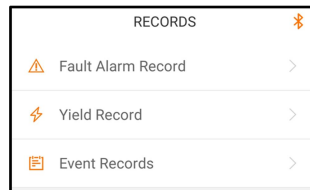

figure 7-6 Records

### Fault Alarm Record

Tap **Fault Alarm Record** to enter the interface, as shown in the following figure.

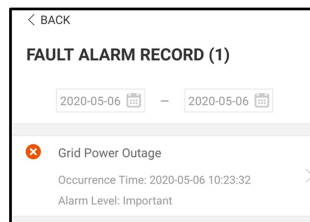



figure 7-7 Fault Alarm Record



Tap  to select a time segment and view corresponding records.  
The inverter can record up to 400 latest entries.

Select one of the records in the list and tap the record to view the detailed fault information as shown in following figure.



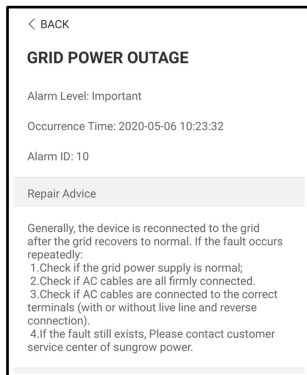

figure 7-8 Detailed Fault Alarm Information

**Yield Record**

Tap **Yield Record** to enter the interface showing daily power generation as shown in the following figure.

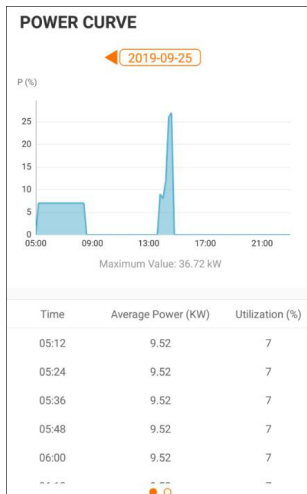

figure 7-9 Power Curve

The App displays power generation records in a variety of forms, including daily power generation histogram,, monthly power generation histogram, annual power generation histogram and total power generation histogram.

table 7-5 Yield Record Explanation

Parameter	Description
Power curve	Show the power output from 5 am to 11 pm in a single day. Each point on the curve represents the percentage of present inverter power to rated power.
Daily yield histogram	Shows the power output every day in the present month.

Parameter	Description
Monthly yield histogram	Shows the power output every month in a year.
Annual yield histogram	Shows the power output every year.

Tap the time bar on the top of the interface to select a time segment and view the corresponding power curve.

Swipe left to check the power yields histogram.

### Event Record

Tap **Event Record** to view event record list.



Tap  to select a time segment and view corresponding records.  
The inverter can record up to 400 latest entries.

## 7.8 More

Tap **More** on the navigation bar to enter the corresponding interface, as shown in the following figure.

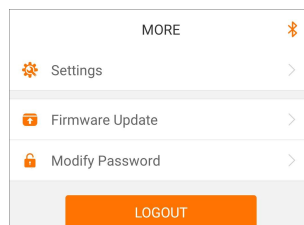

figure 7-10 More

### 7.8.1 System Parameters

Tap **Settings**→**System Parameters** to enter the corresponding interface, as shown in the following figure.

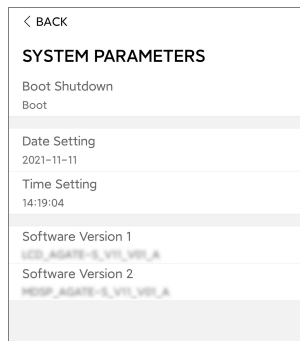

figure 7-11 System Parameters

\* The image shown here is for reference only.

### Boot/Shutdown

Tap **Boot/Shutdown** to send the boot/shutdown instruction to the inverter.

### Date Setting/Time Setting

The correct system time is very important. Wrong system time will directly affect the data logging and power generation value. The clock is in 24-hour format.

### Software Version

Version information of the current firmware.

## 7.8.2 Operation Parameters

### Running Time

Tap **Settings**→**Operation Parameters**→**Running Time** to enter the corresponding interface.

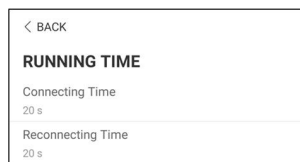

figure 7-12 Running Time

### PID Parameters

Tap **Settings**→**Operation Parameters**→**PID Parameters** to enter the corresponding interface.

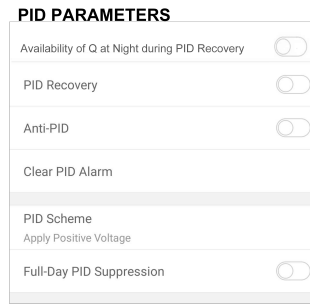

figure 7-13 PID Parameters

table 7-6 PID Parameter Description

Parameter	Description
<b>Availability of Q at Night during PID Recovery</b>	If this switch is turned on, PID recovery and Q at night can be enabled at the same time, but can not work at the same time.
<b>PID Recovery*</b>	Enable/Disable the PID night recovery function. Once enabled, it works between 22:00 pm and 5:00 am by default.
<b>Anti PID</b>	Enable this function of the inverter to protect PV modules from PID effect during the daytime
<b>Clear PID Alarm</b>	If ISO impedance abnormality or PID function exception is detected during running of the PID function, the inverter reports a PID abnormality and reminds the user to take corresponding measures. Clear the alarm report via this parameter once the problems are handled.
<b>PID Scheme</b>	Apply negative or positive voltage.
<b>Full-Day PID Suppression</b>	Enable this function to enable both PID recovery and anti PID.

\*:Please enable both "Availability of Q at Night during PID Recovery" and "PID Recovery" to turn on the PID recovery.

#### NOTICE

Please ensure that the inverter is equipped with DC PID before setting PID parameters. If it is equipped with AC PID, please refer to the EMU200A user manual for PID parameter settings. The PID type of the inverter is subject to the actually received inverter.

### 7.8.3 Power Regulation Parameters

#### Active Power Regulation

Tap **Settings**→**Power Regulation Parameters**→**Active Power Regulation** to enter the interface, as shown in the following figure.

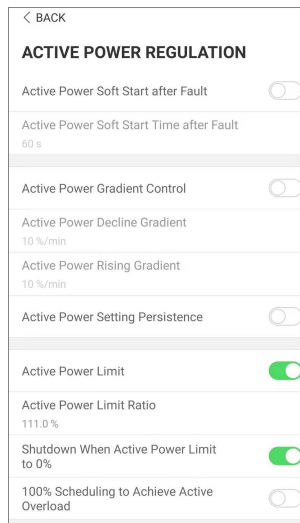

figure 7-14 Active Power Regulation

table 7-7 Active Power Regulation

Parameter	Definition/Setting Description	Range
<b>Active Power Soft Start after Fault</b>	The switch for enabling/disabling the soft start function after a fault occurs.	Enable/Disable
<b>Active Power Soft Start Time after Fault</b>	Time that the soft start takes to raise the power from 0 to 100% rated power.	1s~1200s
<b>Active Power Gradient Control</b>	Select whether to allow setting the active power rate.	Enable/Disable
<b>Active Power Decline Gradient</b>	The decline rate of inverter active power per minute.	1%/min~6000%/min
<b>Active Power Rising Gradient</b>	The rise rate of inverter active power per minute.	1%/min~6000%/min
<b>Active Power Setting Persistence</b>	Select whether to retain the output limited power settings	Enable/Disable
<b>Active Power Limit</b>	The switch for limiting output power.	Enable/Disable
<b>Active Power Limit Ratio</b>	The ratio of limiting output power to rated power in percentage.	0%~110%

Parameter	Definition/Setting Description	Range
<b>Shutdown When Active Power Limit to 0%</b>	Select whether to shut down the inverter when the limited power reaches 0.	Enable/Disable
<b>Active Overload Switch</b>	Switch used to ensure that the inverter operates at the maximum active power when the active power limit ratio is set over 100%.	Enable/Disable

The inverter provides the reactive power regulation function. Enable this function under **Reactive Power Regulation Mode** and select the appropriate mode.

table 7-8 Reactive Power Regulation:

Mode	Descriptions
Off	The PF is fixed at +1.000.
PF	The reactive power can be regulated by the parameter PF (Power Factor).
Qt	The reactive power can be regulated by the parameter Q-Var limits (in %).
Q(P)	The PF changes with the output power of the inverter.
Q(U)	The reactive power changes with the grid voltage.

#### “Off” Mode

The reactive power regulation function is disabled. The PF is limited to +1.000.

#### “PF” Mode

The power factor is fixed and reactive power setpoint is calculated according to the current power. The range of PF is (-1.0 to -0.8) and (+0.8 to +1.0).

Leading: the inverter is sourcing reactive power to the grid.

Lagging: the inverter is injecting reactive power into the grid.

#### “Qt” Mode

In the Qt mode, system rated reactive power is fixed, and the system injects reactive power according to the delivered reactive power ratio. The **Reactive Power Ratio** is set through the App.

The setting range of the reactive power ratio is 0~100% for inductive reactive power regulation or 0~-100% for capacitive reactive power regulation.

#### “Q(P)” Mode

The PF of the inverter output varies in response to the output power of the inverter.

table 7-9 "Q(P)" Mode Parameter Descriptions:

Parameter	Definition/Setting Description	Range
<b>Reactive Response</b>	Switch for enabling/disabling reactive response	Enable/Disable
<b>Reactive Response Time</b>	Completion time of reactive response	0.1s~600.0s
<b>Q(P) Curve</b>	Select corresponding curve according to local regulations	A, B, C*
<b>QP_P1</b>	Output power at P1 on the Q(P) mode curve (in percentage)	0 ~ 100%
<b>QP_P2</b>	Output power at P2 on the Q(P) mode curve (in percentage)	20% ~ 100%
<b>QP_P3</b>	Output power at P3 on the Q(P) mode curve (in percentage)	20% ~ 100%
<b>QP_K1</b>	Power factor at P1 on the Q(P) mode curve	Curve A/C: 0.8 ~ 1
<b>QP_K2</b>	Power factor at P2 on the Q(P) mode curve	Curve B: [-0.600~0.600] *Active Overload Rate/
<b>QP_K3</b>	Power factor at P3 on the Q(P) mode curve	1000
<b>QP_EnterVoltage</b>	Voltage percentage for Q(P) function activation	100% ~ 110%
<b>QP_ExitVoltage</b>	Voltage percentage for Q(P) function deactivation	90% ~ 100%
<b>QP_ExitPower</b>	Power percentage for Q(P) function deactivation	1% ~ 100%
<b>QP_EnableMode</b>	Unconditional activation/deactivation of Q (P) function	Yes / No

\* Curve C is reserved and consistent with Curve A currently.

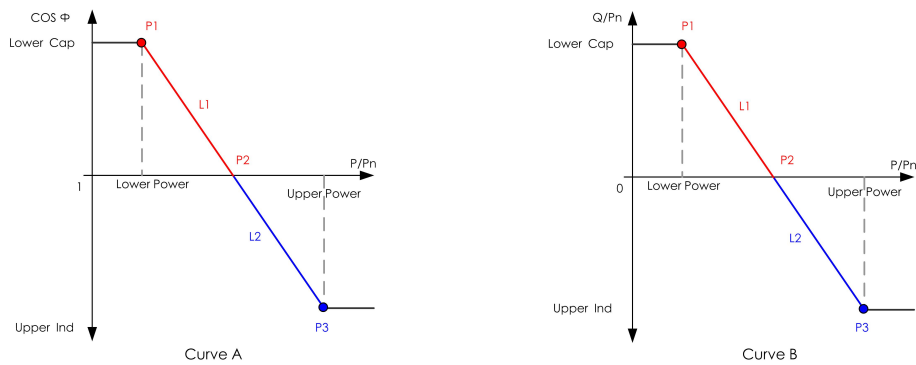

figure 7-15 Q(P) Curve

### “Q(U)” Mode

table 7-10 “Q(U)” Mode Parameter Descriptions:

Parameter	Definition/Setting Description	Range
<b>Reactive Response</b>	Switch for enabling/disabling reactive response	Enable/Disable
<b>Reactive Response Time</b>	Completion time of reactive response	0.1s~600.0s
<b>Q(U) Curve</b>	Select corresponding curve according to local regulations	A, B, C*
<b>Hysteresis Ratio</b>	Voltage hysteresis ratio on the Q(U) mode curve	0 ~ 5%
<b>QU_V1</b>	Grid voltage limit at P1 on the Q(U) mode curve	80% ~ 100%
<b>QU_Q1</b>	Value of Q/Sn at P1 on the Q(U) mode curve	[-60.0%-0]* Overload Rate/ 1000
<b>QU_V2</b>	Grid voltage limit at P2 on the Q(U) mode curve	80% ~ 100%
<b>QU_Q2</b>	Value of Q/Sn at P2 on the Q(U) mode curve	[-60.0%-60.0%]* Overload Rate/ 1000
<b>QU_V3</b>	Grid voltage limit at P3 on the Q(U) mode curve	100% ~ 120%
<b>QU_Q3</b>	Value of Q/Sn at P3 on the Q(U) mode curve	[-60.0%-60.0%]* Overload Rate/ 1000
<b>QU_V4</b>	Grid voltage limit at P4 on the Q(U) mode curve	100% ~ 120%
<b>QU_Q4</b>	Value of Q/Sn at P4 on the Q(U) mode curve	[0-60.0%]* Overload Rate/ 1000
<b>QU_EnterPower</b>	Active power for Q(U) function activation	20% ~ 100%



Parameter	Definition/Setting Description	Range
<b>QU_ExitPower</b>	Active power for Q(U) function deactivation	1% ~ 20%
<b>QU_EnableMode</b>	Unconditional activation/deactivation of Q (U) function	Yes / No / Yes, Limited by PF
<b>QU_Limited PF Value</b>	PF value for Q(U) function activation	0~1.00

\* Curve C is reserved and consistent with Curve A currently.

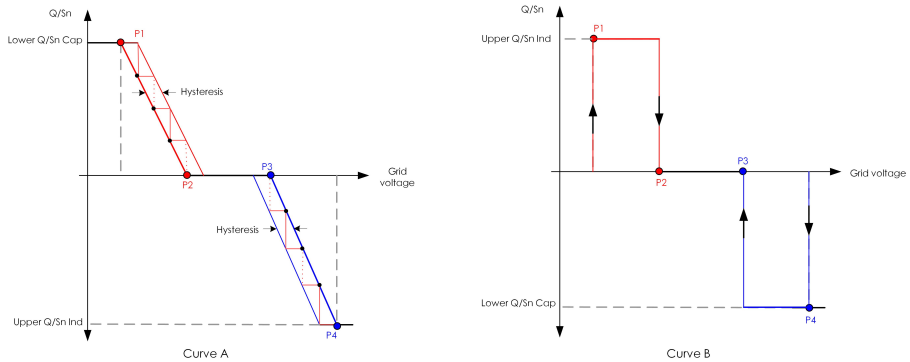

figure 7-16 Q(U) Curve

### 7.8.4 Communication Parameters

#### Serial Port Parameters

Tap **Settings**→**Communication Parameters**→**Serial Port Parameters** to enter the corresponding interface, as shown in the following figure.

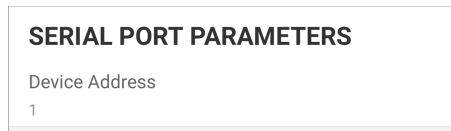

figure 7-17 Serial Port Parameters

table 7-11 Serial Port Parameters

Parameter	Range
<b>Device Address</b>	1–246

#### MPLC Parameters

Tap **Settings**→**Communication Parameters**→**MPLC Parameters** to enter the corresponding interface, as shown in the following figure.

MPLC PARAMETERS	
Band Num	Band1
Array ID	1
Winding ID	1

figure 7-18 MPLC Parameters

table 7-12 MPLC Parameters

Parameter	Range
Band Num	Band1, Band2
Array ID	1–255
Winding ID	1–10

### 7.8.5 Firmware Update

To avoid download failure due to poor on-site network signal, it is recommended to download the firmware package to the mobile device in advance.

- step 1 Enable the "Mobile data" of the mobile device.
- step 2 Open the App, enter the account and password on the login interface. Tap **Login** to enter the home interface.
- step 3 Tap **More**→**Firmware Download** to enter corresponding interface on which you can view the device list.
- step 4 Select the device model before downloading the firmware. Tap the device name in the device list to enter the firmware upgrade package detail interface, and tap  behind the firmware upgrade package to download it.



- step 5 Return to the **Firmware Download** interface, tap  in the upper right corner of the interface to view the downloaded firmware upgrade package.
- step 6 Login the App via local access mode. Refer to "7.3 Login".
- step 7 Tap **More** on the App home interface and then tap **Firmware Update**.
- step 8 Tap the upgrade package file, a prompt box will pop up asking whether to upgrade the firmware with the file, tap **CONFIRM** to perform the firmware upgrade.

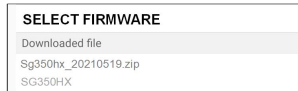

step 9 Wait for the file to be uploaded. When the upgrade is finished, a message is displayed indicating that the upgrade is completed. Tap **Complete** to end the upgrade.

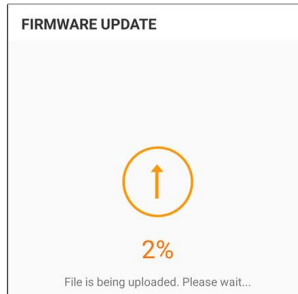

-- End

### 7.8.6 Password Changing

Tap **Modify Password** to enter the modify password interface, as shown in the following figure.

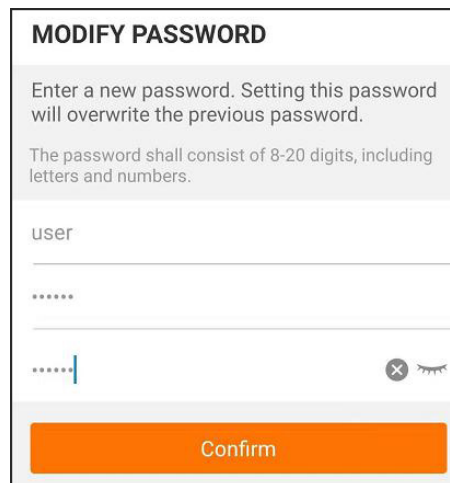

**figure 7-19** Modify Password

The password shall consist of 8–20 digits, including letters and numbers.

## 8 Troubleshooting and Maintenance

### 8.1 Troubleshooting

Once the inverter fails, the fault information is displayed on the App interface. If the inverter is equipped with an LCD screen, the fault information can be viewed on it.

The fault codes and troubleshooting methods of all PV inverters are detailed in the table below, and only some of the faults may occur to the model you purchased. When a fault occurs, you can check the fault information according to the fault code on the mobile app.

Fault Code	Fault Name	Corrective Measures
2, 3, 14, 15	Grid Overvoltage	<p>Generally, the inverter will be reconnected to the grid after the grid returns to normal. If the fault occurs repeatedly:</p> <ol style="list-style-type: none"><li>1. Measure the actual grid voltage, and contact the local electric power company for solutions if the grid voltage is higher than the set value.</li><li>2. Check whether the protection parameters are appropriately set via the App or the LCD. Modify the overvoltage protection values with the consent of the local electric power operator.</li><li>3. Contact Sungrow Customer Service if the preceding causes are ruled out and the fault persists.</li></ol>
4, 5	Grid Undervoltage	<p>Generally, the inverter will be reconnected to the grid after the grid returns to normal. If the fault occurs repeatedly:</p> <ol style="list-style-type: none"><li>1. Measure the actual grid voltage, and contact the local electric power company for solutions if the grid voltage is lower than the set value.</li><li>2. Check whether the protection parameters are appropriately set via the App or the LCD.</li><li>3. Check whether the AC cable is firmly in place.</li><li>4. Contact Sungrow Customer Service if the preceding causes are ruled out and the fault persists.</li></ol>

<b>Fault Code</b>	<b>Fault Name</b>	<b>Corrective Measures</b>
8	Grid Overfrequency	<p>Generally, the inverter will be reconnected to the grid after the grid returns to normal. If the fault occurs repeatedly:</p> <ol style="list-style-type: none"> <li>1. Measure the actual grid frequency, and contact the local electric power company for solutions if the grid frequency is beyond the set range.</li> </ol>
9	Grid Underfrequency	<ol style="list-style-type: none"> <li>2. Check whether the protection parameters are appropriately set via the App or the LCD.</li> <li>3. Contact Sungrow Customer Service if the preceding causes are ruled out and the fault persists.</li> </ol>
10	Grid Power Outage	<p>Generally, the inverter will be reconnected to the grid after the grid returns to normal. If the fault occurs repeatedly:</p> <ol style="list-style-type: none"> <li>1. Check whether the grid supplies power reliably.</li> <li>2. Check whether the AC cable is firmly in place.</li> <li>3. Check whether the AC cable is connected to the correct terminal (whether the live wire and the N wire are correctly in place).</li> <li>4. Check whether the AC circuit breaker is connected.</li> <li>5. Contact Sungrow Customer Service if the preceding causes are ruled out and the fault persists.</li> </ol>
12	Excess Leakage Current	<ol style="list-style-type: none"> <li>1. The fault can be caused by poor sunlight or damp environment, and generally the inverter will be reconnected to the grid after the environment is improved.</li> <li>2. If the environment is normal, check whether the AC and DC cables are well insulated.</li> <li>3. Contact Sungrow Customer Service if the preceding causes are ruled out and the fault persists.</li> </ol>
13	Grid Abnormal	<p>Generally, the inverter will be reconnected to the grid after the grid returns to normal. If the fault occurs repeatedly:</p> <ol style="list-style-type: none"> <li>1. Measure the actual grid, and contact the local electric power company for solutions if the grid parameter exceeds the set range.</li> <li>2. Contact Sungrow Customer Service if the preceding causes are ruled out and the fault persists.</li> </ol>

Fault Code	Fault Name	Corrective Measures
17	Grid Voltage Imbalance	<p>Generally, the inverter will be reconnected to the grid after the grid returns to normal. If the fault occurs repeatedly:</p> <ol style="list-style-type: none"> <li>1. Measure the actual grid voltage. If grid phase voltages differ greatly, contact the electric power company for solutions.</li> <li>2. If the voltage difference between phases is within the permissible range of the local power company, modify the grid voltage imbalance parameter through the App or the LCD.</li> <li>3. Contact Sungrow Customer Service if the preceding causes are ruled out and the fault persists.</li> </ol>
28, 29, 208, 212, 448-479	PV Reserve Connection Fault	<ol style="list-style-type: none"> <li>1. Check whether the corresponding string is of reverse polarity. If so, disconnect the DC switch and adjust the polarity when the string current drops below 0.5 A.</li> <li>2. Contact Sungrow Customer Service if the preceding causes are ruled out and the fault persists.</li> </ol> <p>*The code 28 to code 29 are corresponding to PV1 to PV2 respectively.</p> <p>*The code 448 to code 479 are corresponding to string 1 to string 32 respectively.</p>
532-547, 564-579	PV Reverse Connection Alarm	<ol style="list-style-type: none"> <li>1. Check whether the corresponding string is of reverse polarity. If so, disconnect the DC switch and adjust the polarity when the string current drops below 0.5 A.</li> <li>2. Contact Sungrow Customer Service if the preceding causes are ruled out and the alarm persists.</li> </ol> <p>*The code 532 to code 547 are corresponding to string 1 to string 16 respectively.</p> <p>*The code 564 to code 579 are corresponding to string 17 to string 32 respectively.</p>

Fault Code	Fault Name	Corrective Measures
548-563, 580-595	PV Abnormal Alarm	<p>Check whether the voltage and current of the inverter is abnormal to determine the cause of the alarm.</p> <ol style="list-style-type: none"> <li>1. Check whether the corresponding module is sheltered. If so, remove the shelter and ensure module cleanness.</li> <li>2. Check whether the battery board wiring is loose, if so, make it reliably connected.</li> <li>3. Check if the DC fuse is damaged. If so, replace the fuse.</li> <li>4. Contact Sungrow Customer Service if the preceding causes are ruled out and the alarm persists.</li> </ol> <p>*The code 548 to code 563 are corresponding to string 1 to string 16 respectively.</p> <p>*The code 580 to code 595 are corresponding to string 17 to string 32 respectively.</p>
37	Excessively High Ambient Temperature	<p>Generally, the inverter will resume operation when the internal or module temperature returns to normal. If the fault persists:</p> <ol style="list-style-type: none"> <li>1. Check whether the ambient temperature of the inverter is too high;</li> <li>2. Check whether the inverter is in a well-ventilated place;</li> <li>3. Check whether the inverter is exposed to direct sunlight. Shield it if so;</li> <li>4. Check whether the fan is running properly. Replace the fan if not;</li> <li>5. Contact Sungrow Power Customer Service if the fault is due to other causes and the fault persists.</li> </ol>
43	Excessively Low Ambient Temperature	<p>Stop and disconnect the inverter. Restart the inverter when the ambient temperature rises within the operation temperature range.</p>

Fault Code	Fault Name	Corrective Measures
39	Low System Insulation Resistance	<p>Wait for the inverter to return to normal. If the fault occurs repeatedly:</p> <ol style="list-style-type: none"> <li>1. Check whether the ISO resistance protection value is excessively high via the app or the LCD, and ensure that it complies with the local regulations.</li> <li>2. Check the resistance to ground of the string and DC cable. Take corrective measures in case of short circuit or damaged insulation layer.</li> <li>3. If the cable is normal and the fault occurs on rainy days, check it again when the weather turns fine.</li> <li>4. If there are batteries, check whether battery cables are damaged and whether terminals are loose or in poor contact. If so, replace the damaged cable and secure terminals to ensure a reliable connection.</li> <li>5. Contact Sungrow Customer Service if the preceding causes are ruled out and the fault persists.</li> </ol>
106	Grounding Cable Fault	<ol style="list-style-type: none"> <li>1. Check whether the AC cable is correctly connected.</li> <li>2. Check whether the insulation between the ground cable and the live wire is normal.</li> <li>3. Contact Sungrow Customer Service if the preceding causes are ruled out and the fault persists.</li> </ol>
88	Electric Arc Fault	<ol style="list-style-type: none"> <li>1. Disconnect the DC power supply, and check whether any DC cable is damaged, the connection terminal or fuse is loose or there is a weak contact. If so, replace the damaged cable, fasten the terminal or fuse, and replace the burnt component.</li> <li>2. After performing step 1, reconnect the DC power supply, and clear the electric arc fault via the App or the LCD, after that the inverter will return to normal.</li> <li>3. Contact Sungrow Customer Service if the fault persists.</li> </ol>



Fault Code	Fault Name	Corrective Measures
84	Reverse Connection Alarm of the Meter/CT	<ol style="list-style-type: none"> <li>1. Check if the meter is wrongly connected.</li> <li>2. Check if the input and output wiring of the meter is reversed.</li> <li>3. If the existing system is enabled, please check if the rated power setting of the existing inverter is correct.</li> </ol>
514	Meter Communication Abnormal Alarm	<ol style="list-style-type: none"> <li>1. Check whether the communication cable and the terminals are abnormal. If so, correct them to ensure reliable connection.</li> <li>2. Reconnect the communication cable of the meter.</li> <li>3. Contact Sungrow Customer Service if the preceding causes are ruled out and the alarm persists.</li> </ol>
323	Grid Confrontation	<ol style="list-style-type: none"> <li>1. Check whether the output port is connected to actual grid. Disconnect it from the grid if so.</li> <li>2. Contact Sungrow Customer Service if the preceding causes are ruled out and the fault persists.</li> </ol>
75	Inverter Parallel Communication Alarm	<ol style="list-style-type: none"> <li>1. Check whether the communication cable and the terminals are abnormal. If so, correct them to ensure reliable connection.</li> <li>2. Reconnect the communication cable of the meter.</li> <li>3. Contact Sungrow Customer Service if the preceding causes are ruled out and the alarm persists.</li> </ol>

Fault Code	Fault Name	Corrective Measures
7, 11, 16, 19– 25, 30–34, 36, 38, 40–42, 44– 50, 52–58, 60– 69, 85, 87, 92, 93, 100–105, 107–114, 116– 124, 200–211, 248–255, 300– 322, 324–328, 401–412, 600– 603, 605, 608, 612, 616, 620, 622–624, 800, 802, 804, 807, 1096–1122	System Fault	<ol style="list-style-type: none"> <li>1. Wait for the inverter to return to normal.</li> <li>2. Disconnect the AC and DC switches, and disconnect the battery side switches if there are batteries. Close the AC and DC switches in turn 15 minutes later and restart the system.</li> <li>3. Contact Sungrow Customer Service if the preceding causes are ruled out and the fault persists.</li> </ol>
59, 70–74, 76– 83, 89, 216– 218, 220–233, 432–434, 500– 513, 515–518, 635–638, 900, 901, 910, 911, 996	System Alarm	<ol style="list-style-type: none"> <li>1. The inverter can continue running.</li> <li>2. Check whether the related wiring and terminal are abnormal, check whether there are any foreign materials or other environmental abnormalities, and take corresponding corrective measures when necessary.</li> <li>3. If the fault persists, please contact Sungrow Power Customer Service.</li> </ol>
264-283	MPPT Reverse Connection	<ol style="list-style-type: none"> <li>1. Check whether the corresponding string is of reverse polarity. If so, disconnect the DC switch and adjust the polarity when the string current drops below 0.5 A.</li> <li>2. Contact Sungrow Customer Service if the preceding causes are ruled out and the fault persists.</li> </ol> <p>*The code 264 to code 279 are corresponding to string 1 to string 20 respectively.</p>

Fault Code	Fault Name	Corrective Measures
332-363	Boost Capacitor Overvoltage Alarm	<p>1. The inverter can continue running.</p> <p>2. Check whether the related wiring and terminals are abnormal, check whether there are any foreign materials or other environmental abnormalities, and take corresponding corrective measures when necessary.</p> <p>If the fault persists, please contact Sungrow Power Customer Service.</p>
364-395	Boost Capacitor Overvoltage Fault	<p>1. Disconnect the AC and DC switches, and disconnect the battery side switches if there are batteries. Close the AC and DC switches in turn 15 minutes later and restart the system.</p> <p>2. If the fault persists, please contact Sungrow Power Customer Service.</p>
1548-1579	String Current Reflux	<p>1. Check whether the number of PV modules of the corresponding string is less than other strings. If so, disconnect the DC switch and adjust the PV module configuration when the string current drops below 0.5 A.</p> <p>2. Check whether the PV module is shaded;</p> <p>3. Disconnect the DC switch to check whether the open circuit voltage is normal when the string current drops below 0.5 A. If so, check the wiring and configuration of the PV module,</p> <p>4. Check whether the orientation of the PV module is abnormal.</p>

Fault Code	Fault Name	Corrective Measures
1600 - 1615, 1632 - 1655	PV Grounding Fault	<ol style="list-style-type: none"> <li>1. When the fault occurs, it is forbidden to directly disconnect the DC switch and unplug PV terminals when the direct current is greater than 0.5 A;</li> <li>2. Wait until the direct current of the inverter falls below 0.5 A, then disconnect the DC switch and unplug the faulty strings;</li> <li>3. Do not reinsert the faulty strings before the grounding fault is cleared;</li> <li>4. If the fault is not caused by the foregoing reasons and still exists, contact Sungrow Customer Service.</li> </ol>
1616	System Hardware Fault	<ol style="list-style-type: none"> <li>1. It is prohibited to disconnect the DC switch when the DC current is greater than 0.5 A when the fault occurs.</li> <li>2. Disconnect the DC switch only when the inverter DC side current drops below 0.5 A.</li> <li>3. It is prohibited to power up the inverter again. Please contact Sungrow Customer Service.</li> </ol>



Contact SUNGROW if the measures listed in the “**Troubleshooting Method**” column have been taken but the problem persists.

## 8.2 Maintenance

### 8.2.1 Maintenance Notices

#### DANGER

##### **Risk of inverter damage or personal injury due to incorrect service!**

- **Be sure to use special insulation tools when perform high-voltage operations.**
- **Before maintenance, disconnect the AC circuit breaker on the grid side and then the DC switch. If a fault that may cause personal injury or device damage is found before maintenance, disconnect the AC circuit breaker and wait until the night before operating the DC switch. Otherwise, a fire inside the product or an explosion may occur, causing personal injuries.**
- **After the inverter is powered off for 25 minutes, measure the voltage and current with professional instrument. Only when there is no voltage nor current can operators who wear protective equipment operate and maintain the inverter**
- **Even if the inverter is shut down, it may still be hot and cause burns. Wear protective gloves before operating the inverter after it cools down.**

**⚠ DANGER**

When maintaining the product, it is strictly prohibited to open the product if there is an odor or smoke or if the product appearance is abnormal. If there is no odor, smoke, or obvious abnormal appearance, repair or restart the inverter according to the alarm corrective measures. Avoid standing directly in front of the inverter during maintenance.

**⚠ CAUTION**

To prevent misuse or accidents caused by unrelated personnel: Post prominent warning signs or demarcate safety warning areas around the inverter to prevent accidents caused by misuse.

**NOTICE**

- Restart the inverter only after removing the fault that impairs safety performance.
- As the inverter contains no component parts that can be maintained, never open the enclosure, or replace any internal components.
- To avoid the risk of electric shock, do not perform any other maintenance operations beyond this manual. If necessary, contact SUNGROW for maintenance. Otherwise, the losses caused is not covered by the warranty.

**NOTICE**

Touching the PCB or other static sensitive components may cause damage to the device.

- Do not touch the circuit board unnecessarily.
- Observe the regulations to protect against electrostatic and wear an anti-static wrist strap.

### 8.2.2 Disconnecting Inverter

**⚠ CAUTION**

**Danger of burns!**

Even if the inverter is shut down, it may still be hot and cause burns. Wear protective gloves before operating the inverter after it cools down.

For maintenance or other service work, the inverter must be switched off.

Proceed as follows to disconnect the inverter from the AC and DC power sources. Lethal voltages or damage to the inverter will follow if otherwise.

- step 1 Disconnect the external AC circuit breaker and prevent it from inadvertent reconnection
- step 2 Rotate the DC switch to the "OFF" position for disconnecting all of the PV string inputs.
- step 3 Wait about 25 minutes until the capacitors inside the inverter completely discharge.
- step 4 Ensure that the DC cable is current-free with a current clamp.

-- End

### 8.2.3 Routine Maintenance

Item	Method	Period
Device clean	<p>Check whether the air outlet and heat sink are blocked by dust and other objects.</p> <p>Check if the air inlet and outlet are normal. Clean the air inlet and outlet, if necessary.</p>	<p>Six months to a year (depend on the dust contents in air)</p>
Fans	<p>Check whether there is a fan alarm on the App.</p> <p>Check whether there is any abnormal noise when the fan is rotating.</p> <p>Clean or replace the fans if necessary (see the following section).</p>	Once a year
Cable entry	<p>Check whether the cable entry is insufficiently sealed or the gap is excessively large, and reseal the entry when necessary.</p>	Once a year
Electrical connection	<p>Check whether cables are loose or fall off.</p> <p>Check whether the cable is damaged, especially the part in contact with the metal enclosure.</p>	Six months to a year

### 8.2.4 Cleaning Air Inlet and Outlet

A significant amount of heat is generated when the inverter is working.

In order to maintain good ventilation, please check to make sure the air inlet and outlet are not blocked.

Clean the air inlet and outlet with soft brush or vacuum cleaner if necessary.

## 8.2.5 Fan Maintenance

### **⚠ DANGER**

- **Power off the inverter and disconnect it from all power supplies before maintaining fans.**
- **After the inverter is powered off for 25 minutes, measure the voltage and current with professional instrument. Only when there is no voltage nor current can operators who wear protective equipment operate and maintain the inverter.**
- **Fan maintenance must be performed by professionals.**

Fans inside the inverter are used to cool the inverter during operation. If the fans do not operate normally, the inverter may not be cooled down and inverter efficiency may decrease. Therefore, it is necessary to clean dirty fans and replace the broken fans in a timely manner.

The operation procedure is as follows:

- step 1 Stop the inverter (see "8.2.2 Disconnecting Inverter").
- step 2 Loosen the screw on the sealing plate of the fan module.

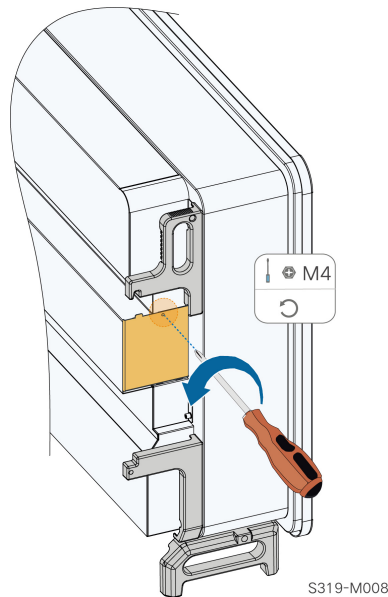

- step 3 Press the tab of the latch hook, unplug the cable connection joint outwards, and loosen the screw on the fan holder.

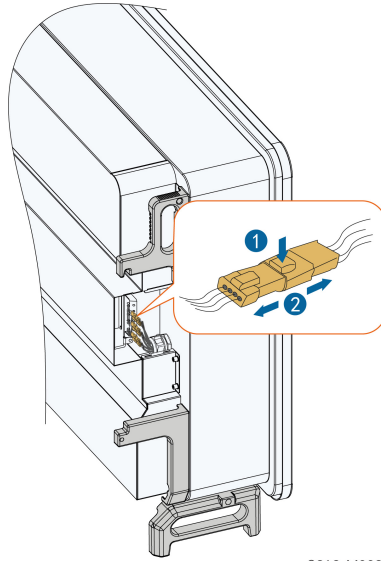

S319-M009

step 4 Loosen screws on the sides of fans.

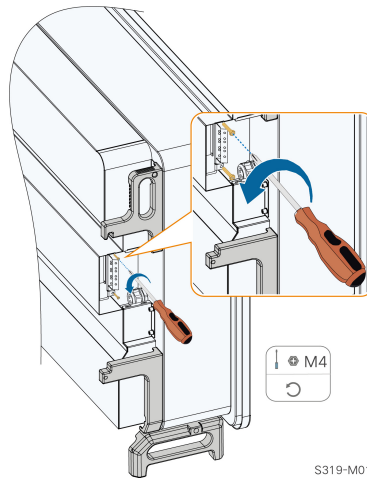

S319-M010

step 5 Pull out the fans. Clean them with a soft brush or vacuum cleaner, and replace them when necessary.



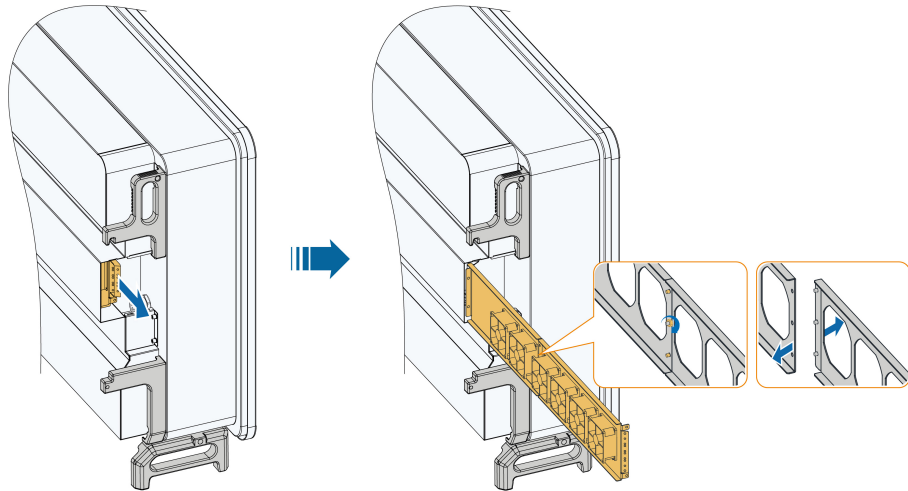

S319-M011



If there is not enough space, pull out part of the fans and remove the screws between the two fans.

-- End

## 8.3 Inverter Disposal

### 8.3.1 Dismantling the Inverter

#### ⚠ CAUTION

**Risk of burn injuries and electric shock!**

**After the inverter is powered off for 25 minutes, measure the voltage and current with professional instrument. Only when there is no voltage nor current can operators who wear protective equipment operate and maintain the inverter.**



- Before dismantling the inverter, disconnect the inverter from both AC and DC power sources.
- If there are more than two layers of inverter DC terminals, dismantle the outer DC connectors before dismantling the inner ones.
- If the original packing materials are available, put the inverter inside them and then seal them using adhesive tape. If the original packing materials are not available, put the inverter inside a cardboard box suitable for the weight and size of this inverter and seal it properly.

step 1 Refer to "[5 Electrical Connection](#)" to disconnect all cables in reverse steps. In particular, when removing the DC connector, use a connector wrench to loosen the locking parts and install waterproof plugs.

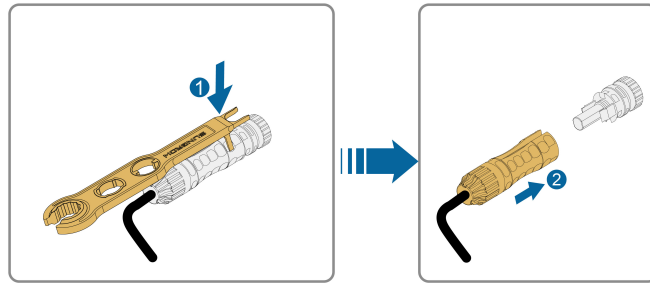

step 2 Refer to "[4 Mechanical Mounting](#)", to dismantle the inverter in reverse steps.

step 3 If necessary, remove the wall-mounting bracket from the wall.

step 4 If the inverter will be used again in the future, please refer to "[3.3 Inverter Storage](#)" for a proper conservation.

-- End

### 8.3.2 Disposal of Inverter

Users take the responsibility for the disposal of the inverter.

#### WARNING

**Please scrap the inverter in accordance with relevant local regulations and standards to avoid property losses or casualties.**

#### NOTICE

**Some parts of the inverter may cause environmental pollution. Please dispose of them in accordance with the disposal regulations for electronic waste applicable at the installation site.**

## 9 Appendix

### 9.1 Technical Data

Parameters	SG285HX	SG320HX
<b>Input (DC)</b>		
Max. PV input voltage	1500 V	1500 V
Min. PV input voltage / Startup input voltage	500 V / 550 V	500 V / 550 V
Nominal PV input voltage	1080 V	1080 V
MPP voltage range	500 V – 1500 V	500 V – 1500 V
No. of independent MPP inputs	12	12 (optional: 16)
Max. number of PV strings per MPPT	2	2
Max. PV input current per MPPT	-	40 A (optional: 30 A for 16 MPPT inputs)
Max. PV input current	12 * 40 A	-
Max. DC short-circuit cur- rent per MPPT	60 A	60 A
<b>Output (AC)</b>		
AC output power	285 kVA @ 40 °C	352 kVA @ 30 °C / 320 kVA @ 40 °C / 295 kVA @ 50 °C
Max. AC output current	206 A	254 A
Nominal AC voltage	3 / PE, 800 V	
AC voltage range	640 – 920V	
Nominal grid frequency / Grid frequency range	50 Hz / 45 – 55 Hz, 60 Hz / 57 – 63 Hz	
THD	< 3 % (at nominal power)	
DC current injection	< 0.5 % In	
Power factor at nominal power / Adjustable power factor	> 0.99 / 0.8 leading – 0.8 lagging	
Feed-in phases / Connec- tion phases	3 / 3	
<b>Efficiency</b>		

Parameters	SG285HX	SG320HX
Max. efficiency / European efficiency	99.02 % / 98.8 %	
<b>Protection</b>		
DC reverse connection protection	Yes	
AC short circuit protection	Yes	
Leakage current protection	Yes	
Grid monitoring	Yes	
Ground fault monitoring	Yes	
DC switch / AC switch	Yes / No	
PV string current monitoring	Yes	
Q at night function	Yes	
Anti-PID and PID recovery function	Optional	
Surge protection	DC Type II / AC Type II	
<b>General Data</b>		
Dimensions (W*H*D)	1136*870*361 mm	
Weight*	≤116 kg	
Isolation method	Transformerless	
Degree of protection	IP66	
Power consumption at night	< 6 W	
Operating ambient temperature range	-30 to 60 °C	
Allowable relative humidity range	0 – 100 %	
Cooling method	Smart forced air cooling	
Max. operating altitude	4000 m (> 3000 m derating)	
Display	LED, Bluetooth+App	
Communication	RS485 / PLC	
DC connection type	MC4-Evo2 (Max. 6 mm <sup>2</sup> , optional 10mm <sup>2</sup> )	
AC connection type	Support OT/DT terminal (Max. 400 mm <sup>2</sup> )	
Grid Support	Q at night function, LVRT, HVRT, active & reactive power control and power ramp rate control	

\*Due to the multi-supplier for some key components, the actual weight may have a ±8% deviation, please refer to the actually delivered product.

Parameters	SG333HX	SG350HX
<b>Input (DC)</b>		
Max. PV input voltage	1500 V	
Min. PV input voltage / Startup input voltage	500 V / 550 V	
Nominal PV input voltage	1080 V	
MPP voltage range	500 V – 1500 V	
No. of independent MPP inputs	12 (optional: 16)	12 (optional: 14/16)
Max. number of PV strings per MPPT	2	2
Max. PV input current	12 * 40 A (Optional: 16 * 30 A)	12 * 40 A (Optional: 14 * 30 A / 16 * 30 A)
Max. DC short-circuit cur- rent per MPPT	60 A	
<b>Output (AC)</b>		
AC output power	333 kVA @ 35 °C / 320 kVA @40 °C	352 kVA @ 30 °C / 320 kVA @ 40 °C / 295 kVA @ 50 °C
Max. AC output current	240.5 A	254 A
Nominal AC voltage	3 / PE, 800 V	
AC voltage range	640 – 920V	
Nominal grid frequency / Grid frequency range	50 Hz / 45 – 55 Hz, 60 Hz / 55 – 65 Hz	
THD	< 3 % (at nominal power)	
DC current injection	< 0.5 % In	
Power factor at nominal power / Adjustable power factor	> 0.99 / 0.8 leading – 0.8 lagging	
Feed-in phases / Connec- tion phases	3 / 3	
<b>Efficiency</b>		
Max. efficiency / European efficiency / CEC efficiency	99.02 % / 98.8 % / –	99.02 % / 98.8 % / 98.5%
<b>Protection</b>		
DC reverse connection protection	Yes	
AC short circuit protection	Yes	
Leakage current protection	Yes	

Parameters	SG333HX	SG350HX
Grid monitoring		Yes
Ground fault monitoring		Yes
DC switch / AC switch		Yes / No
PV string current monitoring		Yes
Q at night function		Yes
Anti-PID and PID recovery function		Optional
Surge protection	DC Type II / AC Type II	
<b>General Data</b>		
Dimensions (W*H*D)	1136 * 870 * 361 mm	1136*870*361 mm (44.7" * 34.3" * 14.2")
Weight*	≤ 116 kg	≤116 kg(≤255.7 lbs)
Isolation method	Transformerless	
Degree of protection	IP66	IP66 (NEMA 4X)
Power consumption at night	< 6 W	
Operating ambient temperature range	-30 to 60°C	-30 to 60°C(-22 to 140 °F)
Allowable relative humidity range	0 – 100 %	
Cooling method	Smart forced air cooling	
Max. operating altitude	4000 m (> 3000 m derating)	4000 m (> 3000 m derating) / 13123 ft (> 9843 ft derating)
Display	LED, Bluetooth+App	
Communication	RS485 / PLC	
DC connection type	MC4-Evo2 (Max. 6 mm <sup>2</sup> , optional 10mm <sup>2</sup> )	MC4-Evo2 (Max. 6 mm <sup>2</sup> , optional 10mm <sup>2</sup> /Max. 10AWG, optional 8AWG )
AC connection type	Support OT/DT terminal (Max. 400 mm <sup>2</sup> )	Support OT/DT terminal (Max. 400 mm <sup>2</sup> / 789 Kcmil)
Grid Support	Q at night function, LVRT, HVRT, active & reactive power control and power ramp rate control, Q-U control, P-f control	

\*Due to the multi-supplier for some key components, the actual weight may have a ±8% deviation, please refer to the actually delivered product.

## 9.2 Wring Distance of DI Dry Contact

The wiring distance between DI dry contact terminals must meet the requirements in the table below. The wiring distance L is the total length of all DI signal cables.

$$L = 2 \sum_{k=1}^n L_k$$

$L_k$  refers to the cable length in one direction between the DI dry contact terminal of the  $k^{\text{th}}$  inverter and the corresponding terminal of the  $(k-1)^{\text{th}}$  inverter.

table 9-1 Correspondence Between Inverter Quantity and Maximum Wiring Distance

Number of Inverter	Maximum Wiring Distance(unit:m)	
	16AWG / 1.31mm <sup>2</sup>	17AWG / 1.026mm <sup>2</sup>
1	13030	10552
2	6515	5276
3	4343	3517
4	3258	2638
5	2606	2110
6	2172	1759
7	1861	1507
8	1629	1319
9	1448	1172
10	1303	1055
11	1185	959
12	1086	879
13	1002	812
14	931	754
15	869	703
16	814	660
17	766	621
18	724	586
19	686	555
20	652	528
21	620	502
22	592	480

Number of Inverter	Maximum Wiring Distance(unit:m)	
	16AWG / 1.31mm <sup>2</sup>	17AWG / 1.026mm <sup>2</sup>
23	567	459
24	543	440
25	521	422

#### NOTICE

In case the specification of the cable used is not included in the table above, when there is only one inverter, ensure that the line impedance of the input node is less than 300Ω; and when there are multiple inverters connected in the daisy chain, ensure that the impedance is less than 300Ω/number of inverter.

### 9.3 Quality Assurance

When product faults occur during the warranty period, SUNGROW will provide free service or replace the product with a new one.

#### Evidence

During the warranty period, the customer shall provide the product purchase invoice and date. In addition, the trademark on the product shall be undamaged and legible. Otherwise, SUNGROW has the right to refuse to honor the quality guarantee.

#### Conditions

- After replacement, unqualified products shall be processed by SUNGROW.
- The customer shall give SUNGROW a reasonable period to repair the faulty device.

#### Exclusion of Liability

In the following circumstances, SUNGROW has the right to refuse to honor the quality guarantee:

- The free warranty period for the whole machine/components has expired.
- The device is damaged during transport.
- The device is incorrectly installed, refitted, or used.
- The device operates in harsh conditions beyond those described in this manual.
- The fault or damage is caused by installation, repairs, modification, or disassembly performed by a service provider or personnel not from SUNGROW.
- The fault or damage is caused by the use of non-standard or non-SUNGROW components or software.
- The installation and use range are beyond stipulations of relevant international standards.



- The damage is caused by unexpected natural factors.

For faulty products in any of above cases, if the customer requests maintenance, paid maintenance service may be provided based on the judgment of SUNGROW.

## 9.4 Contact Information

In case of questions about this product, please contact us.

We need the following information to provide you the best assistance:

- Model of the device
- Serial number of the device
- Fault code/name
- Brief description of the problem

For detailed contact information, please visit: <https://en.sungrowpower.com/contactUS>.

**SUNGROW**

Sungrow Power Supply Co., Ltd.  
[www.sungrowpower.com](http://www.sungrowpower.com)