



PV Grid-tied Inverter
SPI-B-H Series (175K-250K)

User Manual

Copyright © Kehua Data Co., Ltd. 2021. All rights reserved.

No part of this document may be reproduced or transmitted in any form or by any means without prior written consent of Kehua Data Co., Ltd.

Trademarks and Permissions



and other Kehua trademarks are trademarks of Kehua Data Co., Ltd.

All other trademarks and trade names mentioned in this document are the property of their respective holders.

Notice

The purchased products, services and features are stipulated by the contract made between Kehua and the customer. All or part of the products, services and features described in this document may not be within the purchase scope or the usage scope. Unless otherwise specification in the contract, all statements, information, and recommendations in this document are provided “AS IS” without warranties, guarantees or representations of any kind, either express or implied.

The information in this document is subject to change without notice. Every effort has been made in the preparation of this document to ensure accuracy of the contents, but all statements, information, and recommendations in this document do not constitute a warranty of any kind, express or implied.

KEHUA DATA CO.,LTD.

Address:	No.457, Malong Road, Torch High-Tech Industrial Zone, Xiamen, Fujian, China
Website:	www.kehua.com
E-mail:	service@kehua.com
Customer Service Telephone:	400-808-9986
Tel:	0592-5160516
Fax:	0592-5162166

Foreword

Summaries

Thank you for choosing the PV grid-tied inverter (Hereinafter referred to as inverter)!

This document gives a description of the inverter, including appearance, features, working principles, installation, electrical connection, operation, maintenance and storage, etc.

Please save the manual after reading, in order to consult in the future.



NOTE



The figures in this manual are just for reference, for details please see the actual product.





Applicable Model

- SPI175K-B-H
- SPI200K-B-H
- SPI225K-B-H
- SPI250K-B-H

Symbol Conventions

The manual quotes the safety symbols, these symbols used to prompt users to comply with safety matters during installation, operation and maintenance. Safety symbol meaning as follows.

Symbol	Description
 DANGER	Alerts you to a high risk hazard that could, if not avoided, result in serious injury or death.
 WARNING	Alerts you to a medium or low risk hazard that could, if not avoided, result in moderate or minor injury.
 CAUTION	Alerts you to a potentially hazardous situation that could, if not avoided, result in equipment damage, data loss, performance deterioration, or unanticipated results.

Symbol	Description
	Anti-static prompting.
	Be care electric shock prompting.
 TIP	Provides a tip that may help you solve a problem or save time.
 NOTE	Provides additional information to emphasize or supplement important points in the main text.

Product standard: Q/XMHS 003

Contents

1 Safety Description.....	1
1.1 Safety Announcements.....	1
1.1.1 Use Announcements.....	1
1.1.2 PV String Protection	3
1.1.3 ESD Protection.....	3
1.1.4 Grounding Requirements	3
1.1.5 Moistureproof Protection	4
1.1.6 Warning Mark Setting	4
1.1.7 Electrical Connection.....	4
1.1.8 Measurement Under Operation	5
1.2 Operator Requirements	5
2 Overview.....	6
2.1 Product Intro.....	6
2.1.1 Features.....	7
2.1.2 Model Meaning.....	7
2.2 Appearance and Structure	8
2.2.1 Appearance	8
2.2.2 Operation Panel.....	8
2.2.3 Bottom Layout	9
2.2.4 Size	11
2.3 Working Principle.....	11
2.4 Communication	11
2.4.1 Ethernet Communication	11
2.4.2 RS485 Communication.....	12

2.4.3 WIFI/GPRS Communication (Optional).....	13
2.4.4 PLC Communication (Optional).....	14
2.4.5 PID Function (Optional).....	16
3 Installation.....	18
3.1 Installation Process.....	18
3.2 Installation Tools.....	18
3.3 Selection of Installation Site.....	20
3.3.1 Installation Environment.....	20
3.3.2 Installation Clearance.....	21
3.3.3 Requirements for Installation Carrier.....	23
3.3.4 Installation Method.....	23
3.4 Transporting, Unpacking and Checking.....	24
3.4.1 Transporting.....	24
3.4.2 Unpacking and Checking.....	26
3.5 Inverter Installation.....	26
3.5.1 Bracket Installation.....	26
3.5.2 Wall Mounting.....	30
3.6 Electrical Connection.....	34
3.6.1 Safety Announcements.....	34
3.6.2 Requirements for Wire.....	34
3.6.3 External Grounding Connection.....	35
3.6.4 AC Output Wiring.....	37
3.6.5 Internal Grounding Connection.....	42
3.6.6 PV String Input Wiring.....	43
3.6.7 WIFI/GPRS Communication Connection (Optional).....	48
3.6.8 COM. Communication Connection.....	49
3.7 Check the Installation.....	52
4 Startup and Shutdown.....	53
4.1 Check Before Startup.....	53
4.2 Start Inverter.....	53

4.3 Shut Down Inverter	54
5 Maintenance and Troubleshooting	55
5.1 Maintenance	55
5.1.1 Maintenance Details and Period.....	55
5.1.2 Maintenance Guide	56
5.2 Troubleshooting.....	59
6 Stop Running, Dismantle, Discard Inverter	62
6.1 Stop Running.....	62
6.2 Dismantle the Inverter	63
6.3 Discard the Inverter	63
7 Package, Transportation, Storage.....	64
7.1 Package	64
7.2 Transportation	64
7.3 Storage	64
A Technical Specifications	65
B Quality Assurance	75
C Acronyms and Abbreviations	77

1 Safety Description

This chapter mainly describes the safety announcements. Prior to performing any work on the device, please read the user manual carefully, follow the operation and installation instructions and observe all danger, warning and safety information.

1.1 Safety Announcements

This section mainly describes the safety announcements when operation and maintenance. For details, please refer to safety description in relevant chapters.



CAUTION

Before operation, please read the announcements and operation instructions in this section carefully to avoid accident.

The promptings in the user manual, such as "Danger", "Warning", "Caution", etc. don't include all safety announcements. They are just only the supplement of safety announcements when operation.



NOTE

Any device damage caused by violating the general safety operation requirements or safety standards of design, production, and usage will be out of Kehua's guarantee range.

1.1.1 Use Announcements



DANGER

Don't touch terminals or conductors that connected with grid to avoid lethal risk !

**DANGER**

There is no operational part inside the inverter. Please do not open the crust of the inverter by yourself, or it may cause electric shock. The device damage caused by illegal operation is out of the guarantee range.

**DANGER**

After disconnect the input and output of the inverter, there still has residual energy in the storage capacitor, which may cause electric shock. Do not perform the maintenance until all power sources are switched off for 30 minutes.

**WARNING**

Please do not put fingers or tools into the rotating fans to avoid human injury or device damage.

**HIGH TEMPERATURE**

The surface temperature of the inverter may reach to 75°C. During running, please don't touch the surface to avoid scald.

**CAUTION**

No liquid or other objects are allowed to enter the inverter, or, it may cause inverter damage.

**WARNING**

In case of fire, please use dry power fire extinguisher. If using liquid fire extinguisher, it may cause electric shock.

1.1.2 PV String Protection

When install PV string in daytime, it necessary to cover the PV string by light-proof material, or the PV string will generate high voltage under sunshine. If touching PV string accidentally, it may cause electric shock or human injury!



DANGER

There exists dangerous voltage between the positive and negative of PV string!

When installing the device, make sure that the connection between inverter and PV string has been disconnected completely. And set warning mark in the disconnected position to avoid reconnecting.

1.1.3 ESD Protection



CAUTION

To prevent human electrostatic damaging sensitive components (such as circuit board), make sure that you wear a anti-static wrist strap before touching sensitive components, and the other end is well grounded.

1.1.4 Grounding Requirements



WARNING

High leakage risk! The inverter must be grounded before wiring. The grounding terminal must be connected to ground, or, there will be the risk of electric shock when touching the inverter.

- When installing, the inverter must be grounded first. When dismantling, the grounding wire must be removed at last;
- Don't damage the grounding conductor;
- The inverter must be connected to protection grounding permanently.
- Before operation, check the electrical connection to ensure the inverter is grounded reliably.

1.1.5 Moistureproof Protection



CAUTION

Moisture invasion may cause inverter damage!

Observe the following items to ensure the inverter works normally.

- When the air humidity is more than 95%, don't open the door of the inverter;
- In the wet or damp weather, don't open the door of the inverter to maintain or repair.

1.1.6 Warning Mark Setting

In order to avoid accident for unwanted person gets close to the inverter or makes improper operation, observe the following requirements while installing, maintaining or repairing.

- Set warning marks where the switches are to avoid switching them on improperly.
- Set warning signs or safety warning belt in the operation area, which is to avoid human injury or device damage.

1.1.7 Electrical Connection

Electrical connection must be performed according to the description in the user manual and the electrical circuit schematic.



WARNING

The configuration of PV string, grid level, grid frequency, etc. must meet the technical requirements of inverter.

Grid-tied generation should be allowed by the local power supply department and the related operation should be performed by professionals.

All electrical connection must meet the related country and district standard.

1.1.8 Measurement Under Operation



CAUTION

There exists high voltage in the device. If touching device accidentally, it may cause electric shock. So, when perform measurement under operation, it must take protection measure(such as wear insulated gloves, etc.)

The measuring device must meet the following requirements:

- The range and operation requirements of measuring device meets the site requirements;
- The connections for measuring device should be correct and standard to avoid arcing.

1.2 Operator Requirements



CAUTION

The operation and wiring for inverter should be performed by qualified person, which is to ensure that the electrical connection meets the related standards.

The professional technician must meet the following requirements:

- Be trained strictly and understand all safety announcements and master correct operations.
- Fully familiar with the structure and working principle of the whole PV grid-tied generation system.
- Know well about the related standards of local country and district.

2 Overview

This chapter mainly describes product appearance, structure, working principle and communication method, etc.

2.1 Product Intro

The inverter converts the DC energy from PV string into AC energy and then feedbacks to power grid, which is suitable for the large power station grid-tied system. The PV grid-tied generation system consists of PV string, PV grid-tied inverter, transformer and power distribution system, as shown Figure2-1.

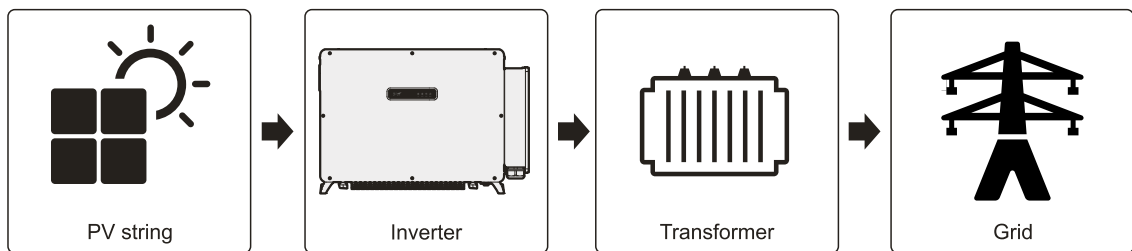

Figure2-1 PV grid-tied generation system



CAUTION

PV grid-tied power generation needs to obtain the permission of local power supply department and performed by professionals.



NOTE

The grid form supported by the inverter is shown in Figure2-2.

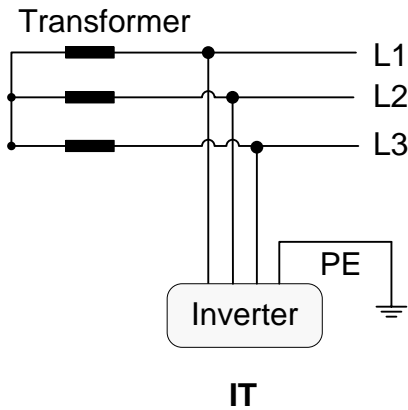

Figure2-2 Grid form

2.1.1 Features

- Innovated three level design, with high transition efficiency.
- Support PLC communication, night SVG function, which satisfies the requirement of grid scheduling.
- The reactive power is adjustable, the range of power factor is $-0.8(\text{lag}) \sim +0.8(\text{ahead})$.
- Smart I-V scanning, fault wave capture, remote online update function.
- Perfect protection functions: island protection, high/low voltage ride through, reverse DC connection protection, AC short circuit protection, leakage current protection, surge protection, etc.

2.1.2 Model Meaning

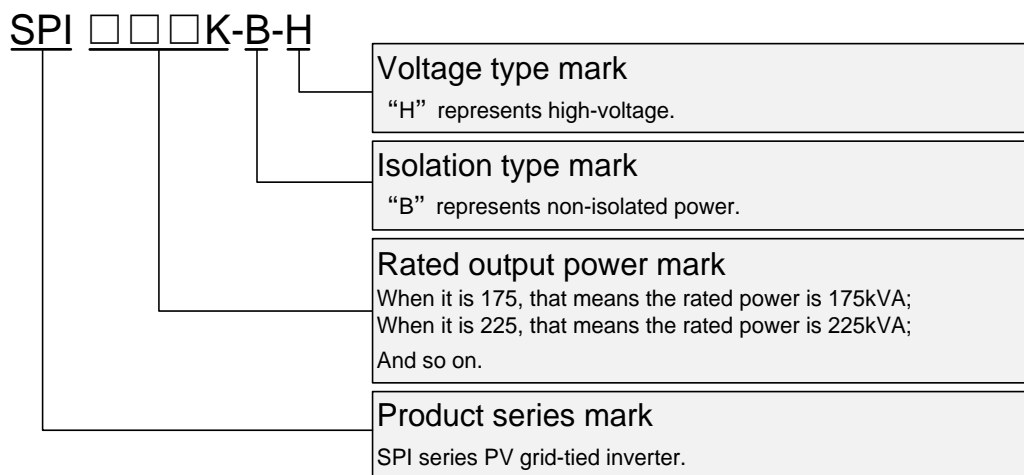

Figure2-3 Model meaning

2.2 Appearance and Structure

2.2.1 Appearance

The appearance of SPI-B-H series string PV grid-tied inverter is as shown in Figure2-4.

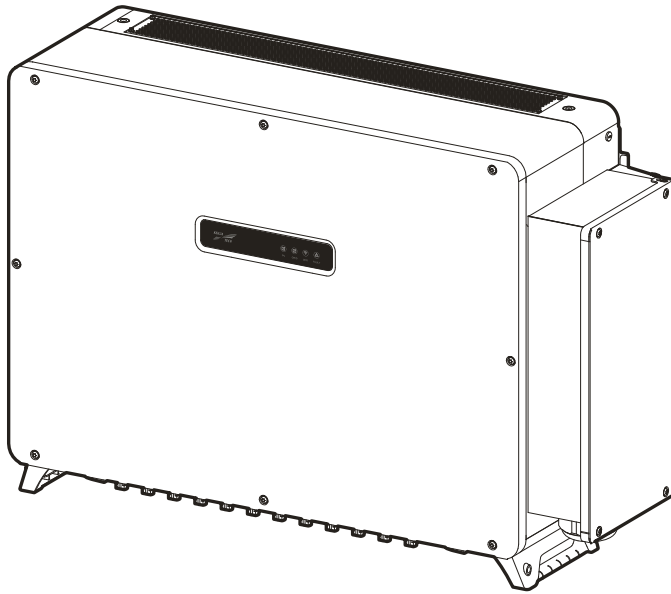

Figure2-4 Appearance

2.2.2 Operation Panel



There are 4 status indicators on the front panel of the inverter, which can indicate the current working status of the inverter. The status of each indicator is shown in Table2-1.



Figure2-5 Operation panel

Table2-1 Indicator status illustration

NO.	Mark	Color	Meaning	Status illustration
①		Green	PV string indicator	ON: At least a group of PV string has been connected. Flicker: Night SVG mode grid-tied status.

NO.	Mark	Color	Meaning	Status illustration
				OFF: All PV strings are disconnected.
②		Green	Grid indicator	ON: Grid-tied status. Flicker: Inverter stay in decrease rated power output status. OFF: No grid-tied status.
③		Green	WiFi/GPRS indicator	ON: WiFi/ GPRS has been connected. OFF: WiFi/ GPRS has been disconnected.
④		Red	Fault indicator	ON: The inverter has alarm.

2.2.3 Bottom Layout

The inverter's bottom layout is shown as Figure2-6.

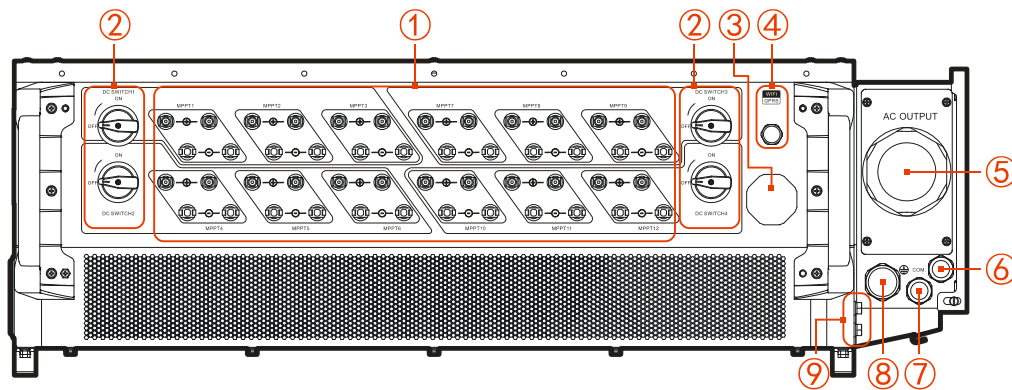



Figure2-6 Bottom layout

 **NOTE**

SPI175K-B-H has 18 groups PV string inputs. The connection identifiers MPPT10+ ~ MPPT12+, MPPT10- ~ MPPT12- in Figure 2-6 are not installed with PV connectors.

The above figure takes SPI225K-B-H as an example to illustrate. If there is no special explanation, the following we will take SPI225K-B-H as an example to explain.

Table2-2 Mark description

NO.	Mark	Name	Remarks
①	MPPT n +/MPPT n -	PV string input terminal	Used to connect PV string input.
②	DC SWITCH	DC switch	It is the connection switch between inverter and PV string. Each DC switch controls the PV string input terminals of marked area.
③	-	Breather valve	Used to balance the pressure difference between inside and outside of the inverter.
④	WIFI/GPRS	WIFI/GPRS interface	Used to WIFI/GPRS connection and communication
⑤	AC OUTPUT	AC output wiring hole	Used to connect the wire of AC output.
⑥	COM.	Communication	Used to connect the communication wire of RS485 or Ethernet.
⑦		wiring hole	
⑧		Internal grounding hole	For internal grounding.
⑨		External grounding terminal	For the grounding of the inverter.

DC Switch

The DC switch (the position is shown as ② in Figure2-6) is the connection switch between the inverter and the PV string, when necessary, it can safely disconnect the connection of the inverter and the PV string. In order to ensure the safety of the operator, make sure that the DC switch is turned off under the following conditions:

- When installing and wiring, the DC switch must be placed to OFF position.
- When checking and repairing, place the DC switch to OFF position and wait for 30 minutes. Use a multimeter to measure the DC bus voltage inside the inverter, only when the voltage lower than 10V, you can perform repair work.

2.2.4 Size

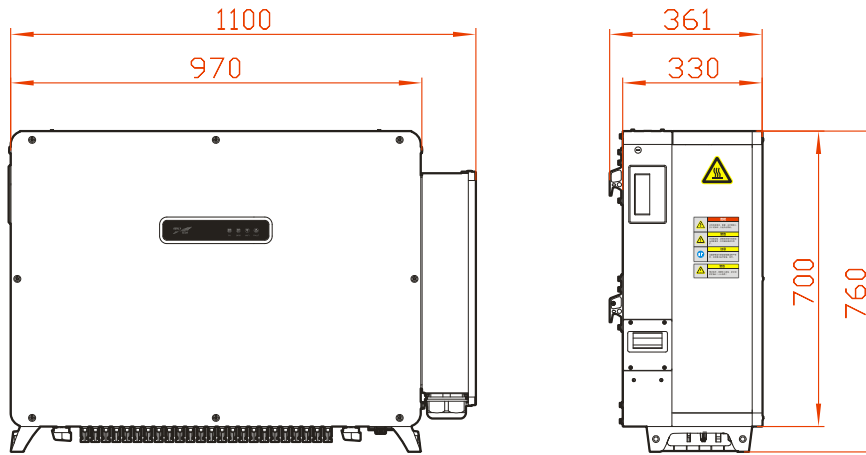

Figure2-7 Size (unit: mm)

2.3 Working Principle

The PV string input is connected to the inverter, and the maximum power point for the PV string is tracked through the internal 12 groups of MPPT circuits to achieve the maximum power output of the PV string, and then the conversion of DC power to three-phase AC power is realized through the inverter circuit, as shown in Figure2-8.

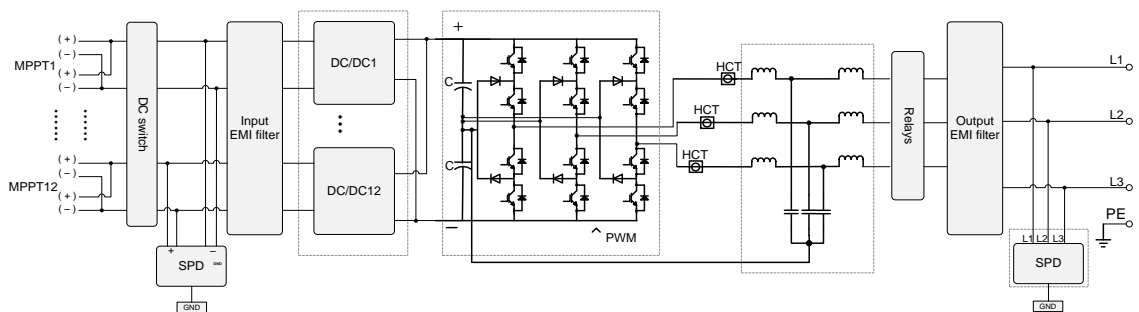

Figure2-8 Working principle diagram

2.4 Communication

The inverter has multiple communication methods, including Ethernet communication, RS485 communication, WIFI/GPRS communication (optional), and PLC communication (optional). Users can easily obtain the current operation data of the inverter.

2.4.1 Ethernet Communication

Ethernet communication (the interface is shown in Figure2-9) is mainly used for local area network monitoring, which can realize the background remote monitoring.

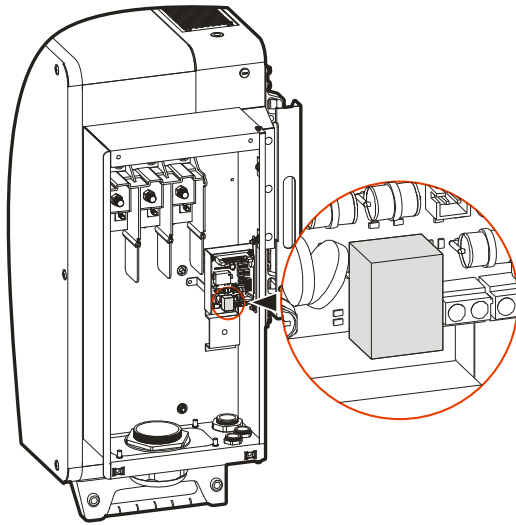

Figure2-9 Ethernet communication interface diagram

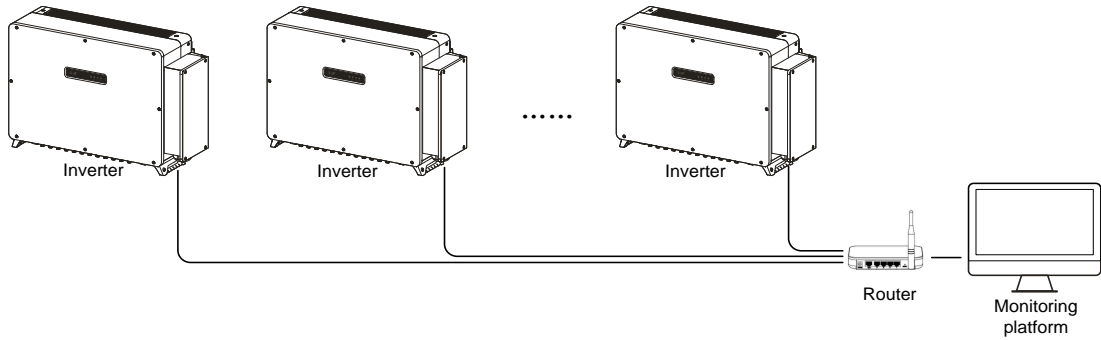

Figure2-10 Ethernet monitoring (multiple inverters)

2.4.2 RS485 Communication

RS485 communication (the interface is shown in Figure2-11) is mainly used for local area network monitoring, which can realize the background remote monitoring.

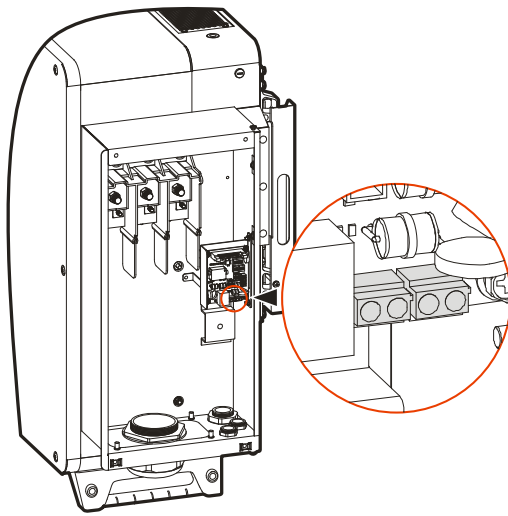

Figure2-11 RS485communication interface diagram

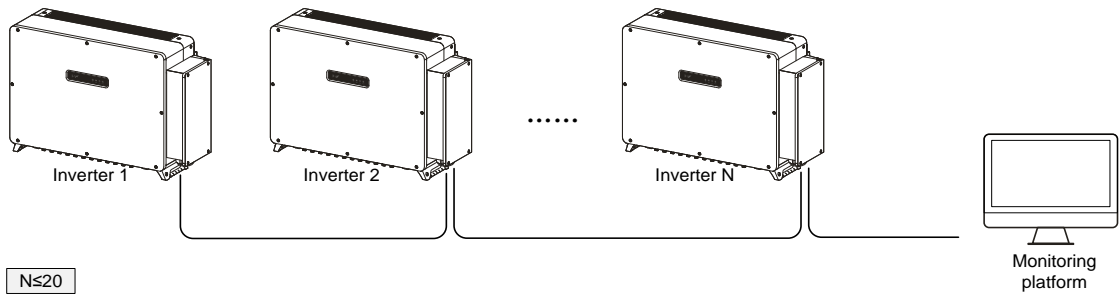

Figure2-12 RS485 communication (multiple inverters)



NOTE

When there is only one inverter communicates via RS485, choose one of the two communication interfaces to connect.

2.4.3 WIFI/GPRS Communication (Optional)

WIFI/GPRS communication is mainly used for remote monitoring, and the running information of the inverter can be monitored through APP on mobile phone or energy cloud on PC. WIFI/GPRS interface is shown as ④ in Figure2-6.

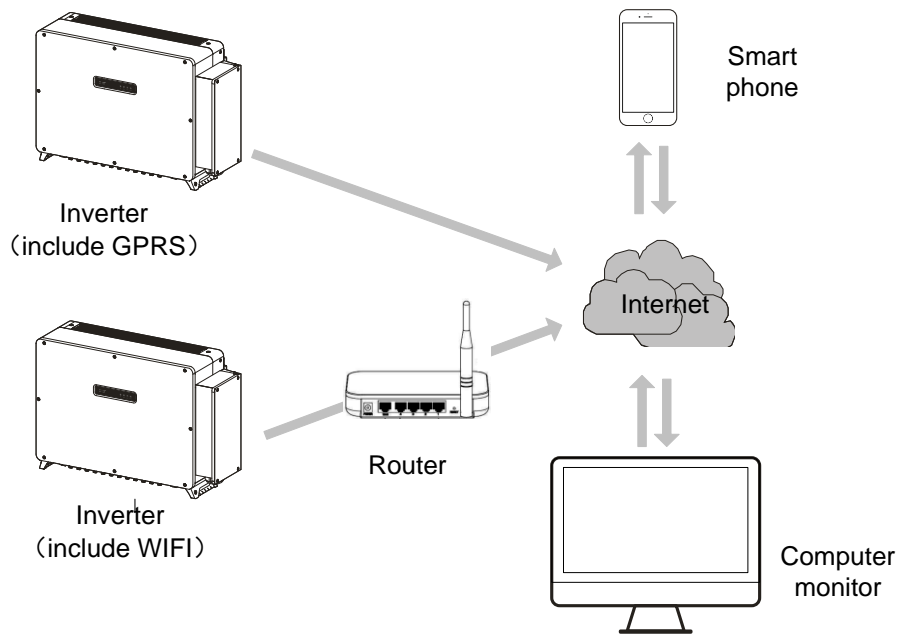

Figure2-13 WIFI/GPRS monitoring solution

NOTE

The APP can build communication between WIFI or GPRS wireless communication module and inverter. Via APP, the near-end and far-end maintenance and monitor of the inverter can come true. User can query the inverter information, alarm, event and set the parameters by the APP.

Download and installation:

- Method 1: download the APP via following application market.
 1. Application market (for Android user).
 2. APP store (iOS).
- Method 2: scan the QR code below to download and install the APP in accordance with the prompting.



Figure2-14 QR code of APP

2.4.4 PLC Communication (Optional)

If the inverter is equipped with PLC communication, Kehua sub-array controller needs to be configured. The output end of the inverter must pass through the isolation transformer and then be connected to grid, as shown in Figure2-15.

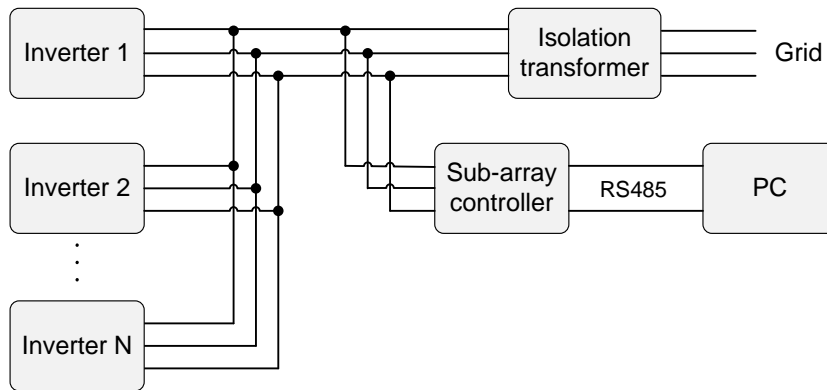

Figure2-15 PLC communication connection

 **NOTE**

The setting of PLC communication address is the same as that of RS485, details please see **3.6.8 COM. Communication Connection**.



CAUTION

If PLC communication is configured, the AC cables can only be multi-core cable, single-core cable cannot be used.

Sub-array controller

Smart sub-array controller is designed base on an outdoor cabinet. Data collector, RS485 signal SPD, PID module and inductor, optical cable terminal box, PLC module, SPD, etc. can be installed in the cabinet to realize the communication and control for sub-array of PV power station.

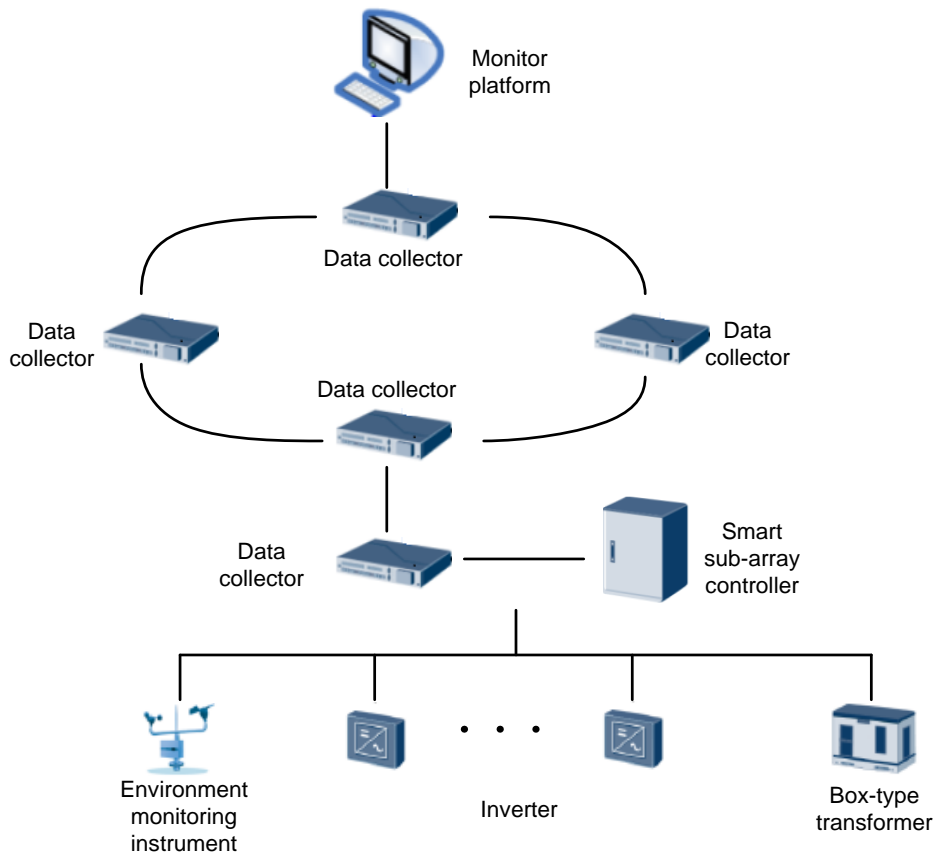

Figure2-16 Network application scheme of smart sub-array controller

2.4.5 PID Function (Optional)

If PID function is configured and enabled, the voltage of all PV string to ground is greater than zero, that is to say, the voltage of all PV string to ground is positive voltage status.



CAUTION

- Before enable PID protection or repair function, please pay attention to the polarity requirement for the voltage of different PV string to ground. If any question, please contact the manufacturer of PV string or read the user manual of PV string.
- When the type of PV string mismatch the voltage scheme of PID protection or repair function, the PID function will not reach the expected effect even cause harmful influence for PV string.

PID repair function

When the inverter not running, the PID function module add reverse voltage for PV string to repair the PV string which has occurred the PID effect.

**NOTE**

After enable PID repair function, it only works at night.

After enable PID repair function, the default voltage of PV string to ground 500Vdc.

3 Installation

This chapter mainly introduces the inverter's installation, including installation process, installation preparation, handling, unpacking and checking, installation procedures, electrical connection. check the installation, etc.

3.1 Installation Process

The installation process of the inverter is as shown in Figure3-1.

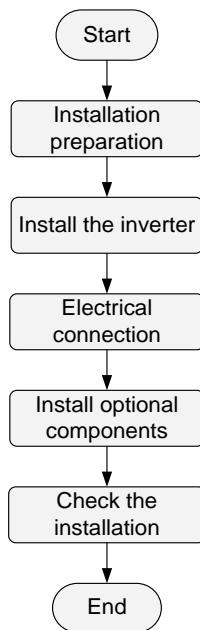

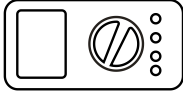

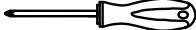







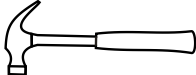
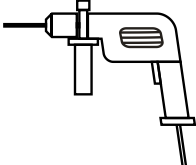
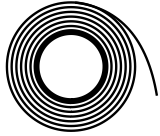
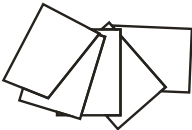

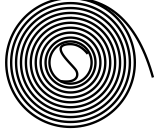
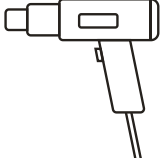

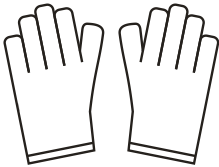
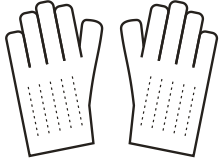
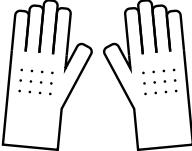
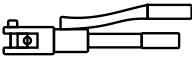

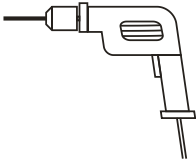
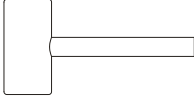



Figure3-1 Installation process

3.2 Installation Tools

The recommended installation tools include but not limited to the following tools, if necessary, you can also use other auxiliary tools according to the site conditions.

Tools			
			
Clamp meter	Multi-meter	Label paper	Phillips screwdriver
			
Flat-headscrewdriver	Socket wrench	Adjustable wrench	Torque wrench
			
COAX crimping tool	Diagonal pliers	Wire stripper	Claw hammer
			
Hammer drill	Insulation tape	Cotton cloth	Brush
			
Heat shrink tubing	Heat gun	Electrician's knife	Protective gloves
			
ESD gloves	Insulated gloves	Hydraulic pliers	Cable tie

Tools			
 Electric drill	 Rubber hammer	 Wrench	

**CAUTION**

The installation tools need to be insulated to avoid electric shock.

**NOTE**

Multimeter range $\geq 1500\text{Vdc}$.

Wrench specification: T30.

3.3 Selection of Installation Site

3.3.1 Installation Environment

The use environment has a certain influence on the service life and reliability of the inverter. Therefore, please pay attention to avoid using it in following working environment.

- Do not install the inverter in high or low temperature or humid places that exceed the technical specifications (temperature: $-35^{\circ}\text{C}\sim 60^{\circ}\text{C}$, relative humidity: 0%~100%)
- Do not install the inverter in closed space, ensure good ventilation around the inverter.
- There must be no flammable or explosive materials or with dust, corrosive substances, or salt in the installation environment

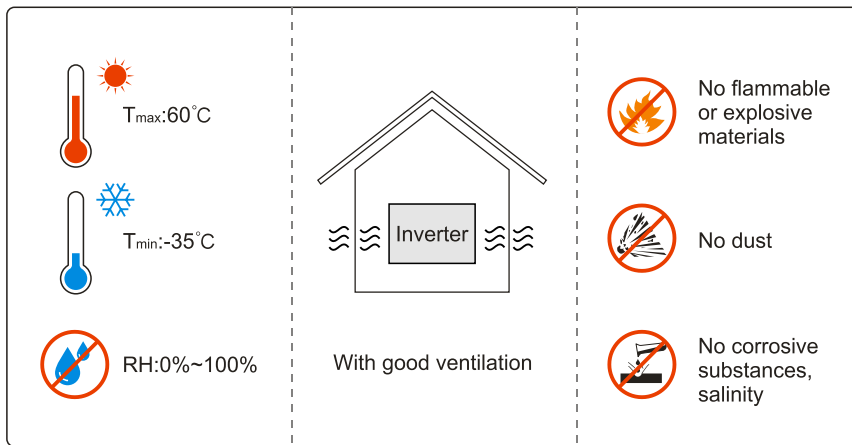

Figure3-2 Installation environment requirements

- As the operation of inverter will produce noise pollution, avoid installing them near residential areas as far as possible.

NOTE

Choose the best installation location for the inverter, which plays a very important role in its safe operation, service life, performance guarantee, etc. Therefore, it is recommended to choose a place that can avoid direct sunlight, rain, and snow. As shown in Figure3-3.

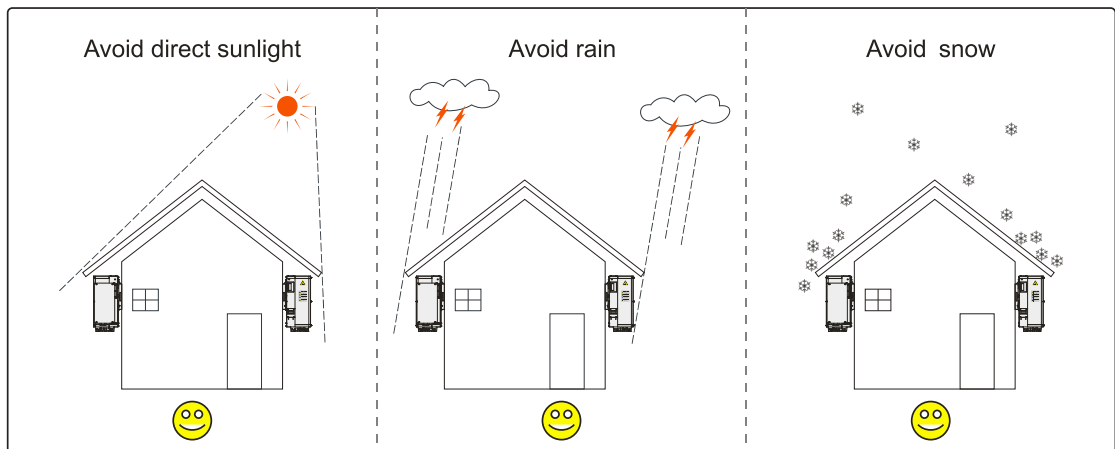

Figure3-3 Recommended installation location

3.3.2 Installation Clearance

- Keep a clearance of at least 800mm from the left side and right side of the inverter to other objects, keep at least 600mm from the top of the inverter to ceiling and at least 450mm from the bottom of the inverter to ground, which is good for heat dissipation or maintenance, as shown in Figure3-4.

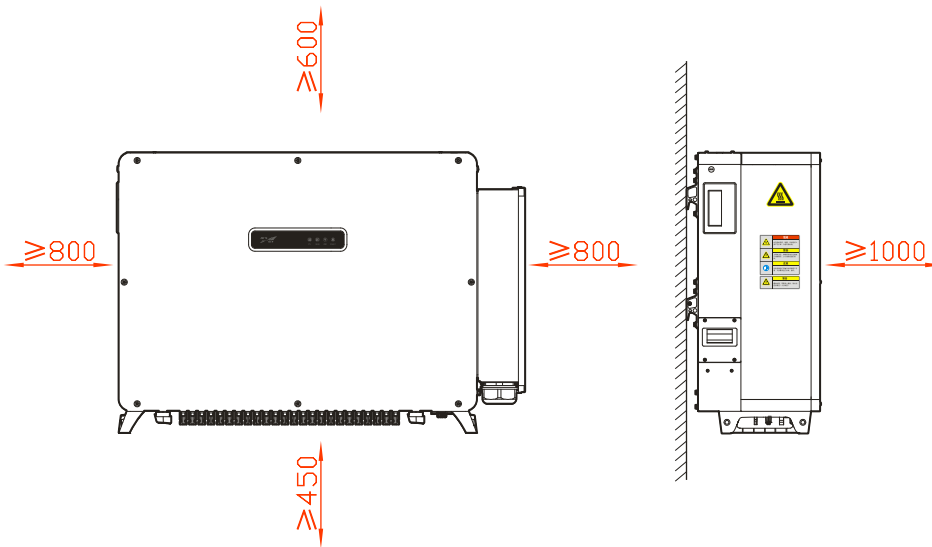

Figure3-4 Installation clearance

NOTE

The installation height of the inverter should be easy to check the status of the indicator lights, connect wires, operate and maintain, etc. The recommended space between bottom inverter and ground is 600~800mm.



CAUTION

We suggest not installing the inverter at upper and lowering at the same time, which is to avoid influence the heat dissipation of the inverter.

- When multiple inverters are installed side by side, a certain distance must be reserved between the inverters, as shown in Figure3-5.

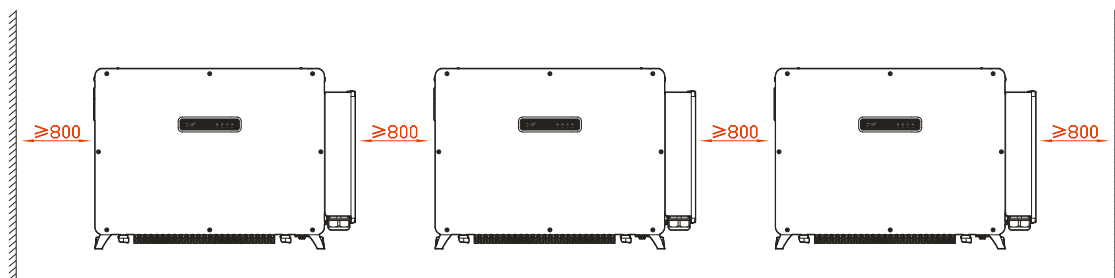

Figure3-5 Installation space requirements of multiple inverters (unit: mm)

- When the inverters are installed back to back, a certain distance must be reserved between the two inverters, as shown in Figure3-6.

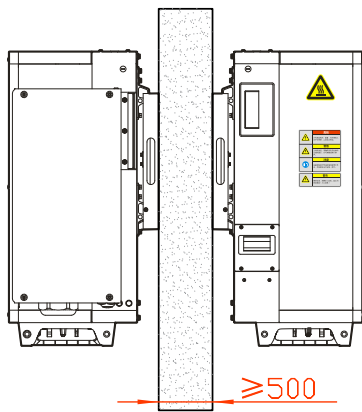

Figure3-6 Back-to-back installation space requirements (unit: mm)

3.3.3 Requirements for Installation Carrier

The installation carrier of the inverter (such as walls and brackets) should meet the requirements shown in Figure3-7.



Installation carrier can not be flammable material



Max load-bearing of installation carrier should be not less than 4 times weight of inverter

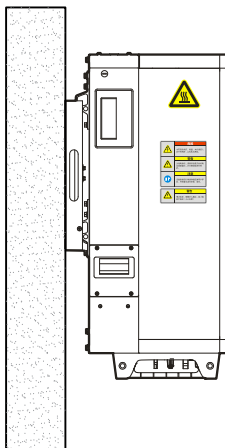

Figure3-7 Installation carrier requirements

3.3.4 Installation Method

It is recommended to install the inverter vertically or obliquely backwards (with an angle of $\leq 15^\circ$ from the vertical plane). It cannot be tilted forward or inverted installed.

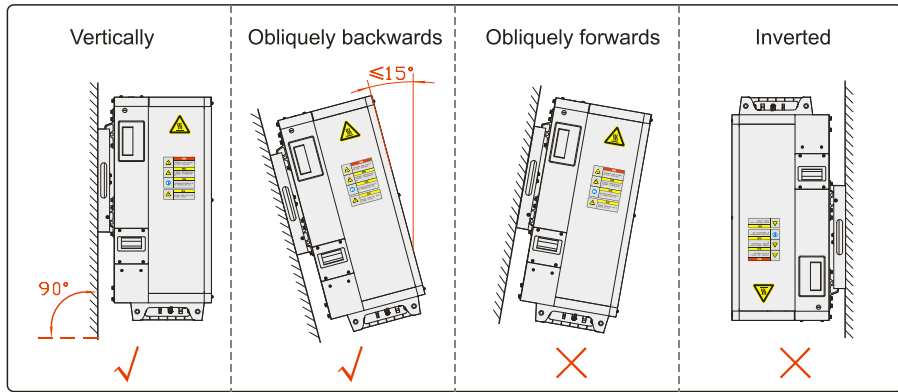

Figure3-8 Illustration of installation method



CAUTION

Because the inverter is downward air inlet and the upper air outlet, in order to ensure the normal operation of the inverter, it is not recommended to install it horizontally.

3.4 Transporting, Unpacking and Checking

3.4.1 Transporting

Before installation, the inverter needs to be transported to the selected installation site. When transporting, you can carry the inverter by the handle or the ring according to the scene.

Handle transporting

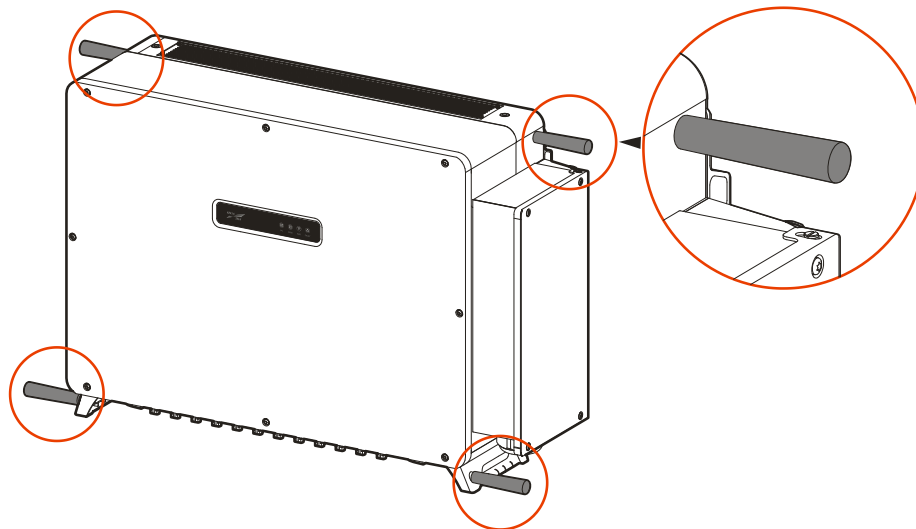

Figure3-9 Handle transporting

**NOTE**

The handle is an accessory. When transporting, they need to be installed to corresponding position and tightened.

It is recommended that carry the inverter by at least 4 people and wear protective equipment such as smash-proof shoes and gloves.

**CAUTION**

- While handling, move the inverter carefully to avoid impact or fall.
- During transporting, always pay attention to the gravity center of the inverter, do not suddenly put it down or lift it up.
- Putting the inverter directly on a hard ground will damage the terminals of the inverter or the case, it is necessary to lay protective materials such as sponge pads or foam underneath it.

Ring transporting

Figure3-10 Ring transporting

**NOTE**

The hoist ring is an optional accessory. When the hoist rings are required for transportation, they must be selected first, and install them onto the top of the inverter tightly on the site.

**CAUTION**

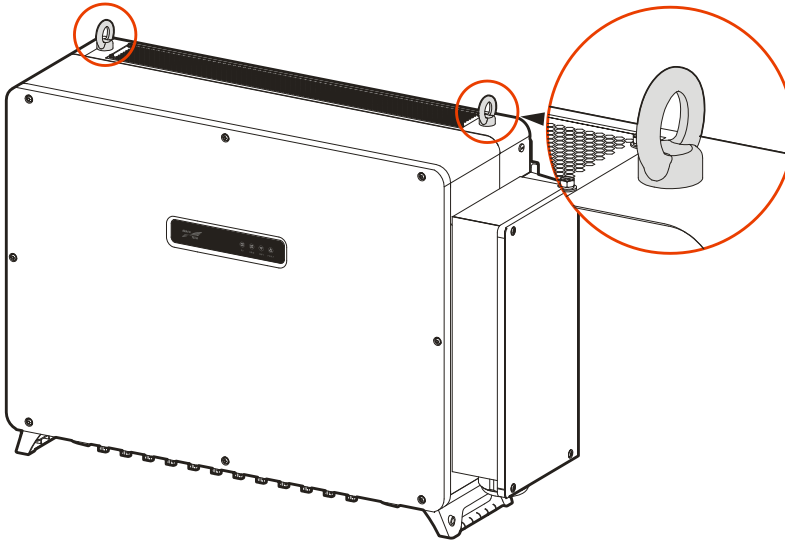
While hoisting, keep balance and avoid collision with walls or other objects. In case of severe weather conditions, such as heavy rain, heavy fog, strong wind, etc., the hoisting operation should be stopped.

3.4.2 Unpacking and Checking

**NOTE**

Determine the unpacking site in advance. Normally, the unpacking site should be as close to installation position as possible.

The inverter has been completely tested and strictly inspected before leaving the factory, but damage may still occur during transporting, so a detailed inspection is required after arrival.

- Inspect the inverter's appearance for shipping damage, if any shipping damage is found, report it to the carrier immediately.
- Check if the types of the accessories are complete and correct. If there is any discrepancy, take notes and contact the distributor immediately.

**CAUTION**

After unpacking, if the inverter will be stored for a long time, it's recommended to pack the inverter with original plastic package.

----End

3.5 Inverter Installation

The inverter can be installed on the wall or metal bracket via equipped installation holder.

3.5.1 Bracket Installation

- Step 1 Use the four M4*10 combination bolts in accessories to fix the installation holder with the joint lever, as shown in Figure3-11.

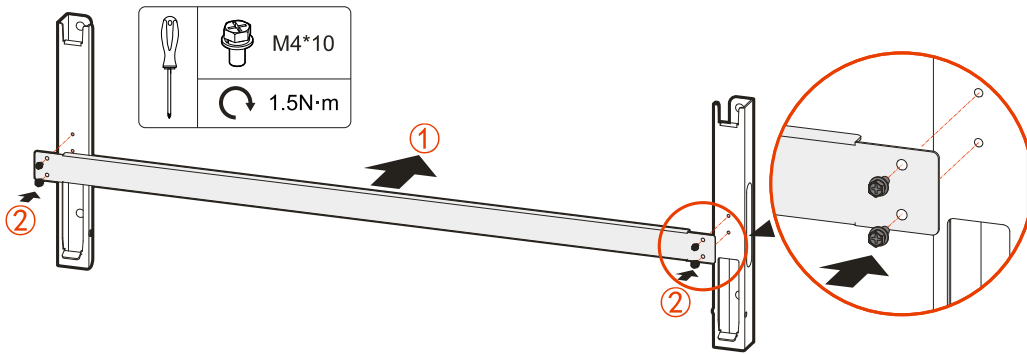

Figure3-11 Assemble installation holder

Step 2 Place the assembled installation holder onto the installation site, use a horizontal ruler to adjust the angle, and mark the position of the hole on the bracket, as shown in Figure3-12.



CAUTION

Please ensure that the wall mount is level to ensure that the mounting holes are consistent and aligned.

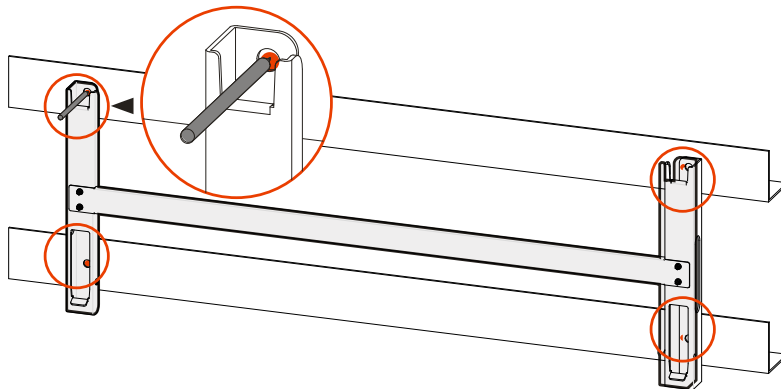

Figure3-12 Mark the mounting holes position



NOTE

You can also directly mark the location of the holes according to the size of the mounting holes (see Figure3-13).

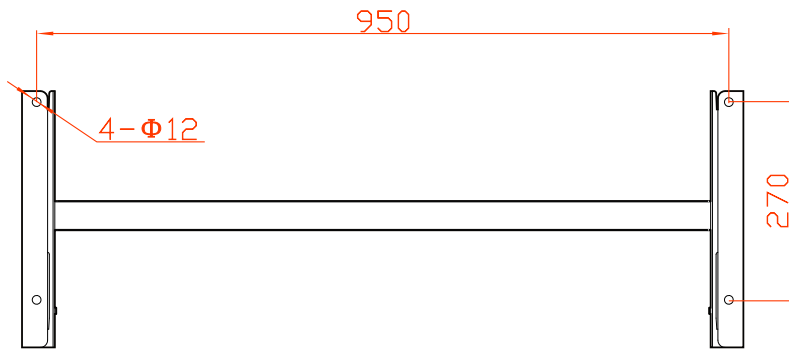

Figure3-13 Mounting hole size (unit: mm)

Step 3 Use the electric drill to drill holes on the bracket according to the marked position. The drilling size is $\Phi 12\text{mm}$, as shown in Figure3-14.

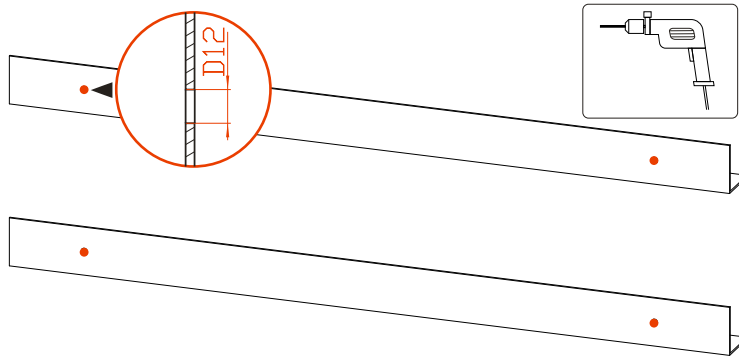

Figure3-14 Drilling holes (unit: mm)

Step 4 Fix the installation holder to the bracket, use M10*40 bolts, put on flat washers, spring washers and nuts, and then tighten the nuts clockwise with a wrench, as shown in Figure3-15.

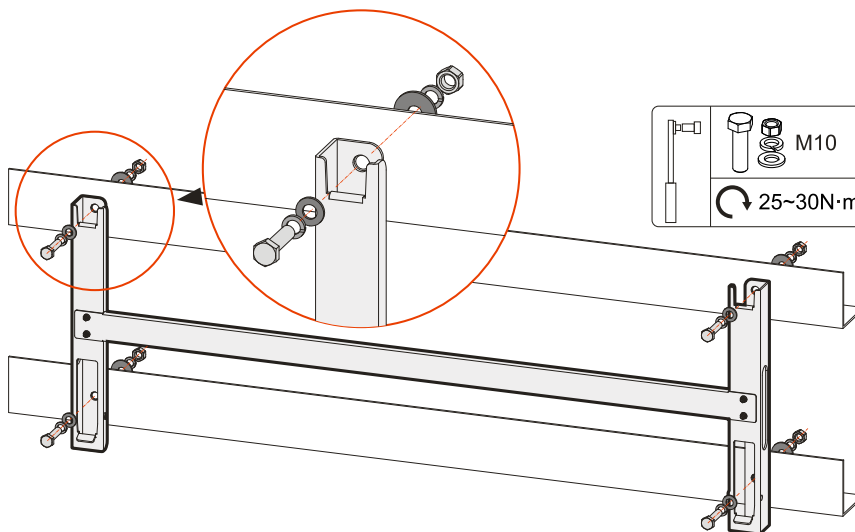

Figure3-15 Fix installation holder

- Step 5 Lift the inverter to the installation holder, make sure that the mounting ears of the inverter and the groove of the installation holder fit well, and then slowly hang the inverter to the installation holder, as shown in Figure3-16.

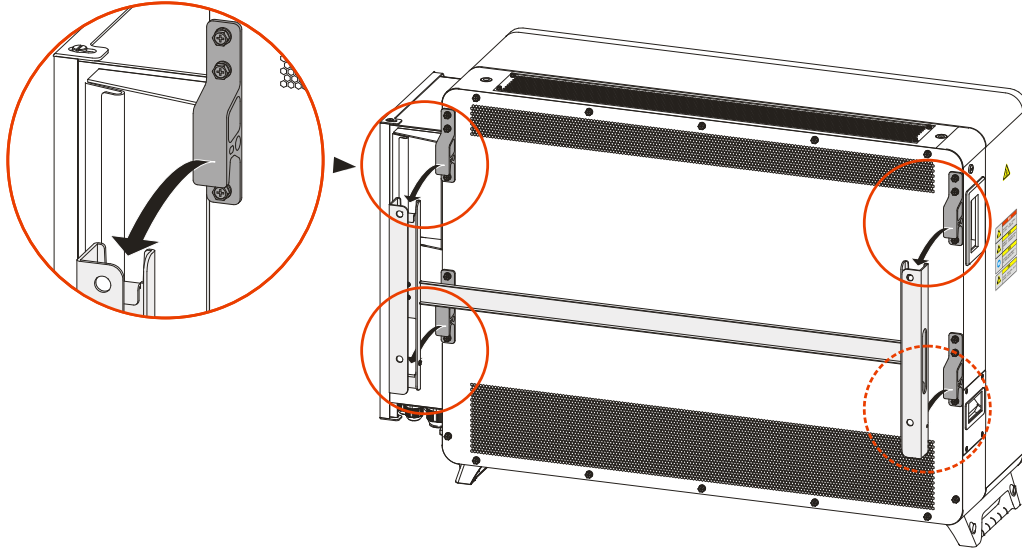

Figure3-16 Hang the inverter onto the installation holder



CAUTION

Do not loosen the inverter until it fixed firmly.

- Step 6 Use the screws M5*50 in the accessories to fix the inverter, as shown in Figure3-17.

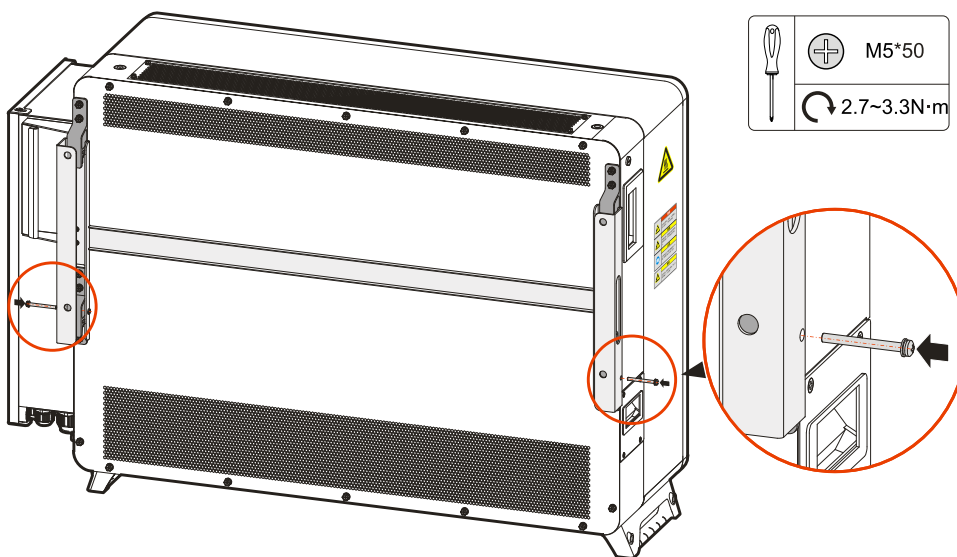

Figure3-17 Fix inverter

----End

3.5.2 Wall Mounting

- Step 1 Use the four M4*10 combination bolts in accessories to fix the installation holder with the joint lever, as shown in Figure3-18.

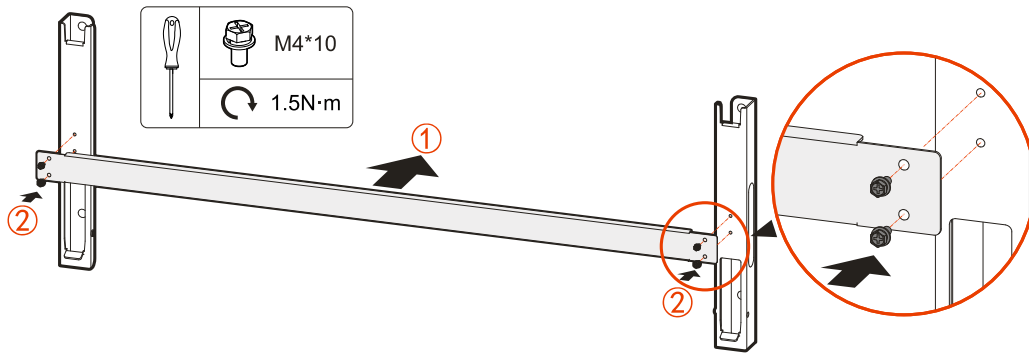

Figure3-18 Assemble installation holder

- Step 2 Place the assembled installation holder onto the installation site, use a horizontal ruler to adjust the angle, and mark the position of the hole on the wall, as shown in Figure3-19.



CAUTION

Keep the installation holder horizontal and ensure that the mounting holes are consistent and aligned.

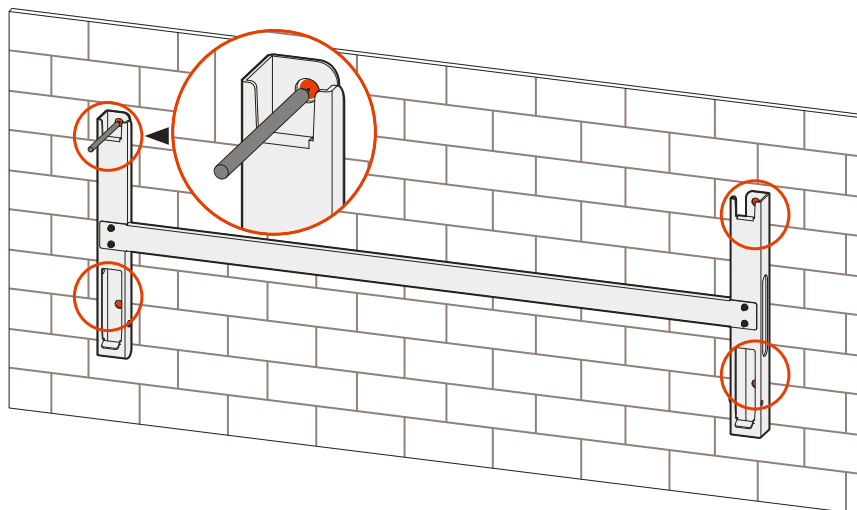

Figure3-19 Mark the mounting holes position

 **NOTE**

You can also directly mark the location of the holes according to the size of the mounting holes (see Figure3-20).

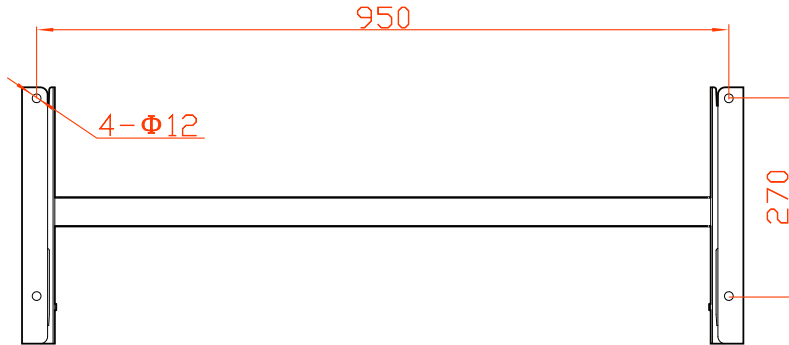

Figure3-20 Mounting hole size(unit: mm)

Step 3 According to the marked position, use a hammer drill to drill holes on the wall. Drilling hole size is $\Phi 14.5\text{mm}$, depth range is 55~60mm.

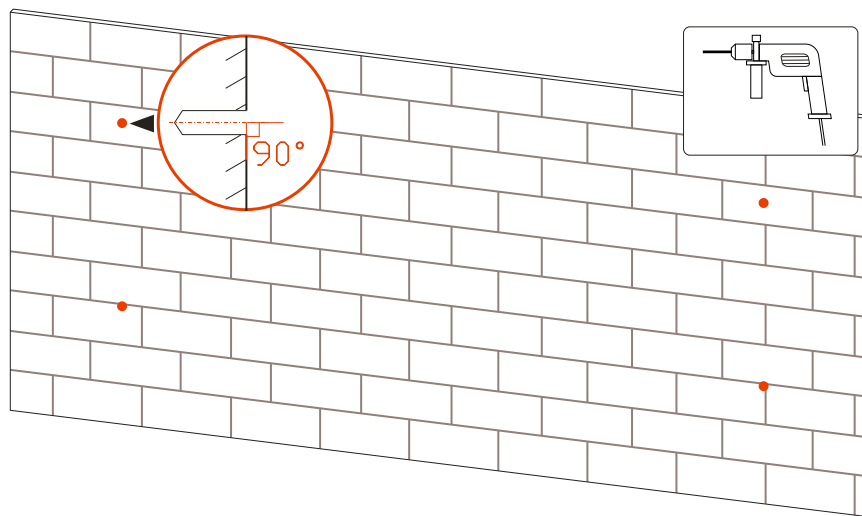

Figure3-21 Drilling holes



CAUTION

After drilling, please clean the residues in the holes, and measure the depth of each hole to ensure that the depth of each hole is the same.

Step 4 Install expansion bolts. Install the four M10*80 expansion bolts into the installation holes, as shown in Figure3-22.

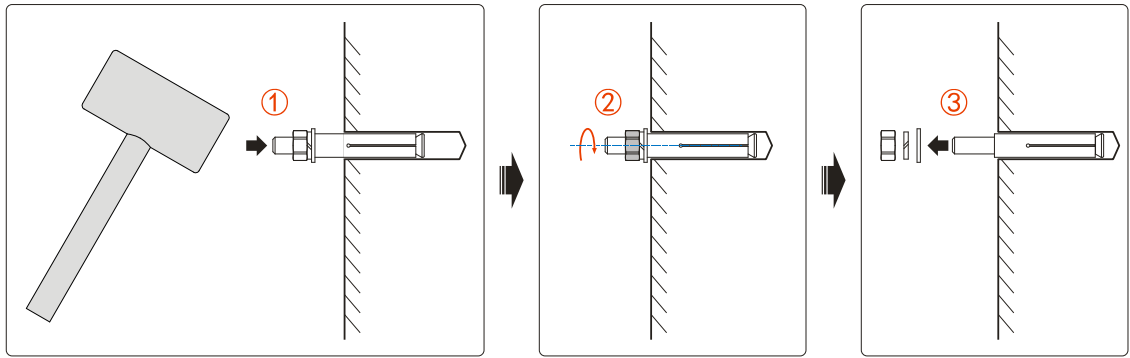

Figure3-22 Expansion bolt installation diagram

- Step 5 Install the installation holder. Fix the installation holder to the expansion bolts, put on flat washers, spring washers and nuts, and then tighten the nuts clockwise with a wrench, as shown in Figure3-23.

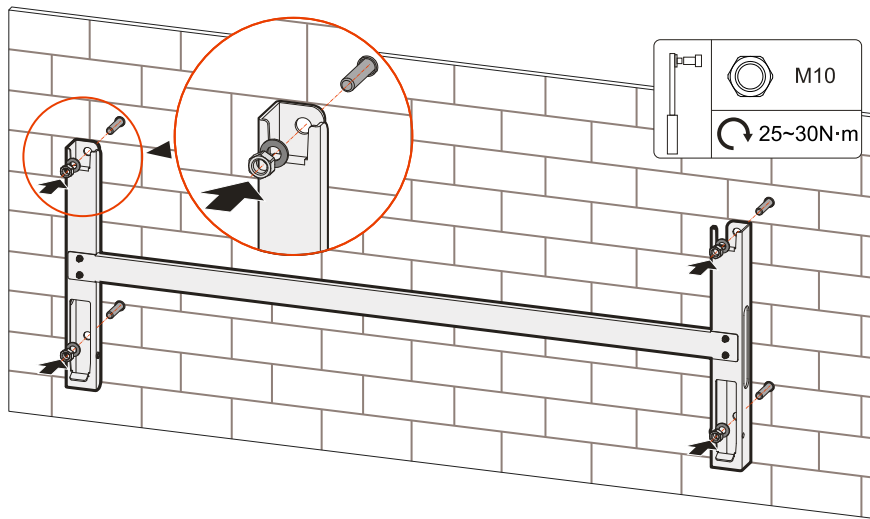

Figure3-23 Fix the installation holder

- Step 6 Lift the inverter to the installation holder, make sure that the mounting ears of the inverter and the groove of the installation holder fit well, and then slowly hang the inverter to the installation holder, as shown in Figure3-24.

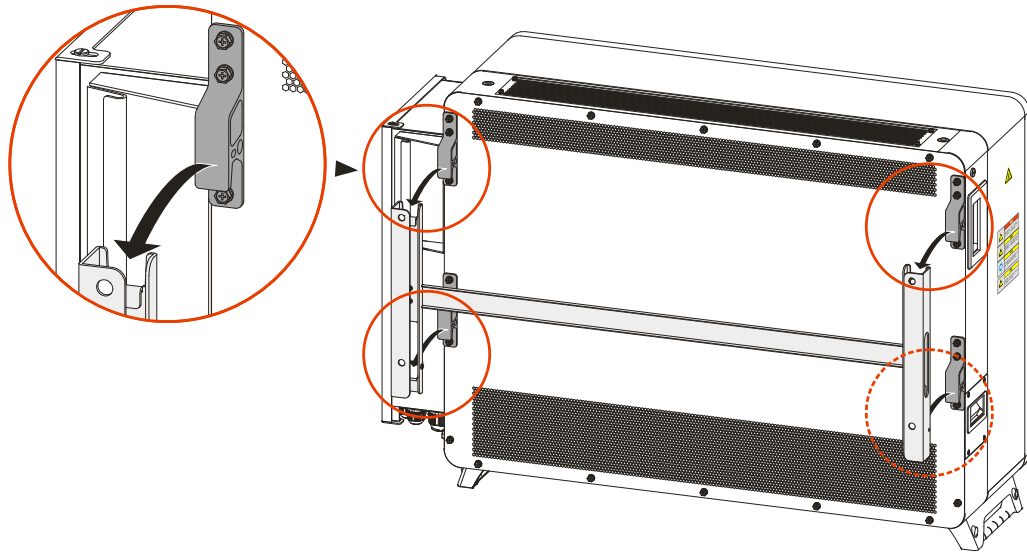

Figure3-24 Hang the inverter onto the installation holder



CAUTION

After confirming that the inverter is fixed firmly, the operator can release the equipment.

Step 7 Use the screws M5*50 in the accessories to fix the inverter, as shown in Figure3-25.

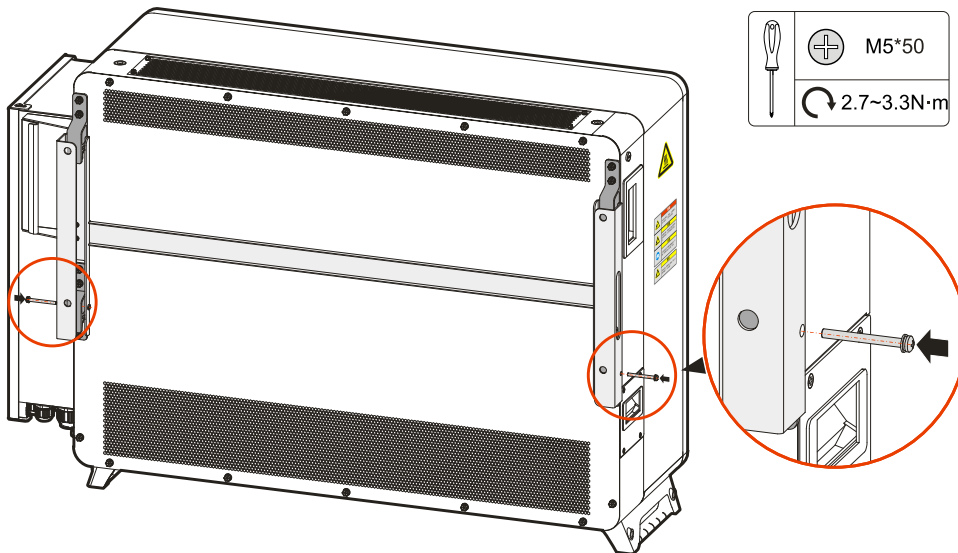

Figure3-25 Fix inverter

----End

3.6 Electrical Connection

3.6.1 Safety Announcements

During operating, professionals must wear protective equipment.



DANGER

- High voltage may exist in the inverter.
 - PV string exposed to sunlight will generate dangerous voltage.
 - Do not close the DC switches and external AC breaker before completing the electrical connection.
 - Make sure that all cables without electricity before wiring.
-



WARNING

- Any improper operation during wiring may cause equipment damage or human injury, so, wiring operation must be performed only by professional technicians.
 - The cables used in the PV power generation system must be firmly connected, intact, well insulated and with appropriate specifications.
-



CAUTION

- The wiring process must follow the relevant rules of the local power grid and the relevant safety instructions of the PV string.
 - All electrical installations must comply with the electrical standards of the country or local region.
 - The inverter can only be integrated into the power grid after obtaining permission from the local power department.
-

3.6.2 Requirements for Wire

The wiring terminals are located at the bottom of the inverter (as shown in Figure2-6), The recommended wires and terminals are as shown in Table3-1.

Table3-1 Wire and terminal requirements

Name	Type	Recommended wire diameter (mm ²)
PV string input wire	1500V and above PV cables	4~6
AC output wire	Outdoor multi-core cable or single-core cable	Outdoor three-core/four-core cable: 70~240 (Max. outer diameter<56mm); Outdoor single-core cable: 70~300 (Max. outer diameter<30mm).
Internal grounding wire	Outdoor cable	Conductor cross-sectional area $\geq S/2$ (S is the conductor cross-sectional area of AC output wire) (Max. outer diameter <25mm)
Ethernet communication wire	8-core network cable	-
RS485 communication wire	Shielded twisted pair	2*0.3 mm ² (Maximum outer diameter<14mm)
External grounding wire	Outdoor cable	Conductor cross-sectional area $\geq S/2$ (S is the conductor cross-sectional area of AC output wire)

 **NOTE**

- The cables in above table are based on UL copper wire. If other wires are used, please replace them according to the standard. The wire materials selected by our company have passed the national standard certification or UL certification.
- If the recommended terminal model is not adopted, please confirm with our company.
- If using the aluminum wire, it should adopt copper-aluminum transition terminal.

3.6.3 External Grounding Connection



WARNING

- Since the inverter is with no transformer, it is required that the positive and negative poles of the PV string cannot be grounded, otherwise the inverter will not operate normally.
- Before the AC side, PV string and communication connection, please connect the external grounding wire first.
- The grounding connection of the external grounding terminal cannot replace the connection of the internal grounding terminal. Make sure that both of them are grounded reliably, otherwise Kehua Company will not in charge of the responsibility for possible consequences.

Step 1 Strip the insulation layer of the grounding wire by crimping tool, and press it into the corresponding terminal, as shown in Figure3-26.

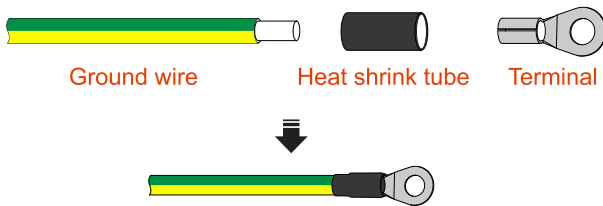

Figure3-26 Grounding wire stripping diagram



NOTE

It is recommended to use DT or OT terminal for the external grounding wire.

Step 2 Connect the crimped grounding wire to the external grounding terminal at the bottom of the inverter, as shown in Figure3-27.

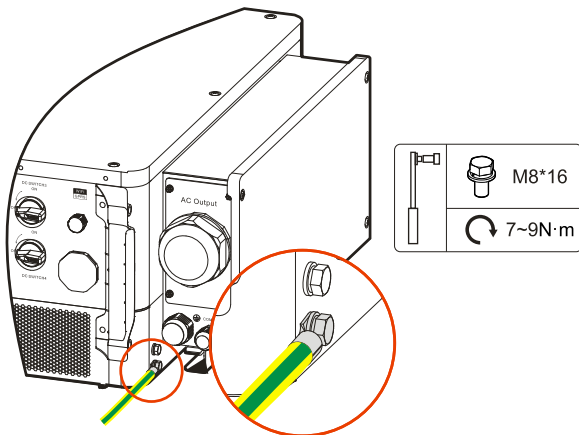

Figure3-27 Schematic diagram of the ground connection

 **NOTE**

Two external grounding terminals are reserved at the bottom of the inverter, at least one of them should be connected.

In order to improve the anti-corrosion performance of the grounding terminal, it is recommended to paint anti-rust paint on the outside of the grounding terminal for protection after installation.

**CAUTION**

- The grounding of the inverter and the lightning rod of the building that inverter installed cannot be the same, the two need to be separated (as shown in Figure 3-28), or, lightning stroke will damage the inverter.
- The grounding of the inverter should be directly connected to the grounding system, and the impedance should be less than 20mΩ.

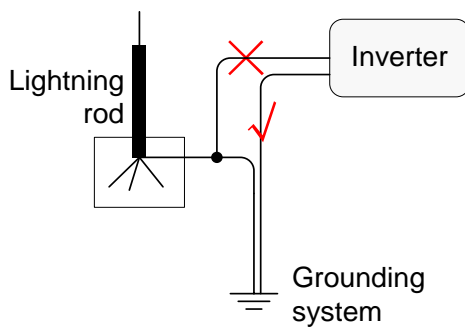

Figure 3-28 Grounding diagram of inverter

----End

3.6.4 AC Output Wiring

**CAUTION**

Before connecting to the grid, first make sure that the grid voltage and frequency meet the requirements of the inverter. For details, please see *A Technical Specifications*. Otherwise, please contact the electricity company to solve.

Each inverter should be equipped with an independent external three-pole breaker on the AC side to ensure that the inverter is safely disconnected from the grid. Recommended breaker's rated voltage is 800V, rated current is 250A.

**NOTE**

If several inverters need to share a breaker, the breaker needs to be selected according to the total current.

**CAUTION**

No load can be connected between the inverter and the breaker.

Medium-voltage transformer

The configured medium-voltage transformer must meet the following requirements:

- The selected transformer can be distribution transformer, which matches the PV system of typical periodicity load (that is to say, in daytime, there is load, at night, there is no load). You can choose dry type transformer or oil-immersed transformer, shielding winding is not required.
- The line voltage at low-voltage side of the transformer must meet the output line voltage of inverter's AC side. When connecting with IT type grid, the ground resistance requirements of the winding at low-voltage side of boost transformer, AC wires and secondary device (including relay protection device, detection meter and related auxiliary equipment) must not less than 1100V.
- The output line voltage at high voltage side of the transformer must be in accord with the voltage level of local grid. We suggest selecting the transformer with tapped switch at the high voltage side.
- When the temperature around the transformer is 45°C, the transformer should be able to operate for a long time under 1.1 times overload. The selected transformer must be with overload protection and short circuit protection.
- It is recommended to use the transformer whose short circuit impedance equal to 6% (allowable error $\pm 10\%$), and at the same time, the voltage drop of system wires should be not more than 3%.
- The bearable DC component of the transformer should be 1% of the fundamental current in rated power.
- The apparent power of inverter cannot exceed the power of the transformer. Considering the max. AC current of all paralleled inverters.

- Considering the bearable ability of the transformer if system faults. The fault includes system short circuit, grounding fault, voltage drop, etc.
- When selecting and installing the transformer, the environment condition, such as temperature, humidity, altitude, air quality, of local site must be taken into account.

Terminal requirements

- When the AC output uses copper wire, it is recommended to use DT/OT terminals (as shown in Figure3-29). The terminal specifications and requirements is: $13\text{mm} \leq A \leq 15.5\text{mm}$, $B \leq 46\text{mm}$, $C \leq 22\text{mm}$.

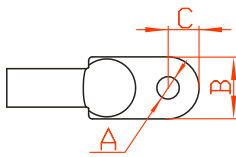

Figure3-29 Terminal size requirements

- When the AC output uses aluminum wire, copper-aluminum transition terminal is required to avoid direct contact between the copper bar and the aluminum wire.

Wiring steps



CAUTION

Before wiring, add marks for AC output cables to avoid wrong connection.

- Step 1 Open the cover of the right-side wiring box by wrench, as shown in Figure3-30.

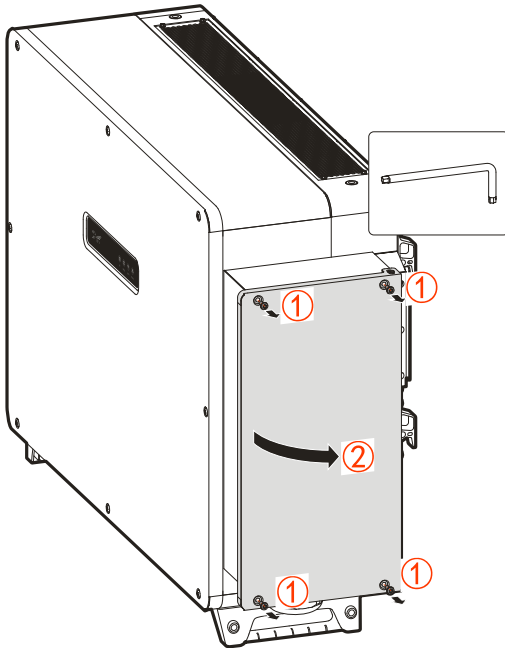

Figure3-30 Open the wiring cover

 **NOTE**

A limiting lever is designed inside the wiring box. After the wiring cover is opened, the limiting lever needs to be fixed (as shown in Figure Figure3-31) to facilitate the wiring operation.

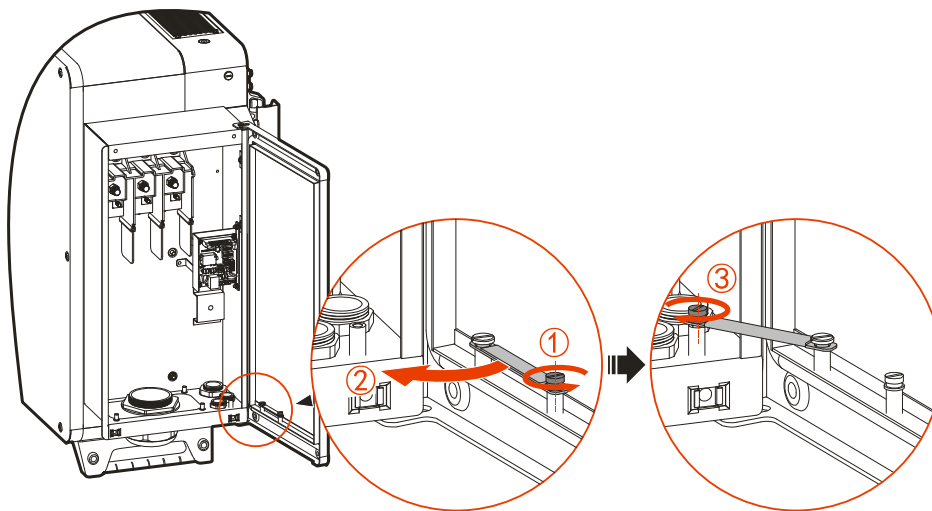

Figure3-31 Operation diagram of limiting lever

- Step 2 Loosen the external forced cable fixing head of AC terminal, lead the L1, L2, L3 wires go through the external forced cable fixing head, and use a wire stripper to strip the L1, L2 and L3 respectively, and crimp them to the terminal, and then connect to the AC output terminal block, as shown in Figure3-32.

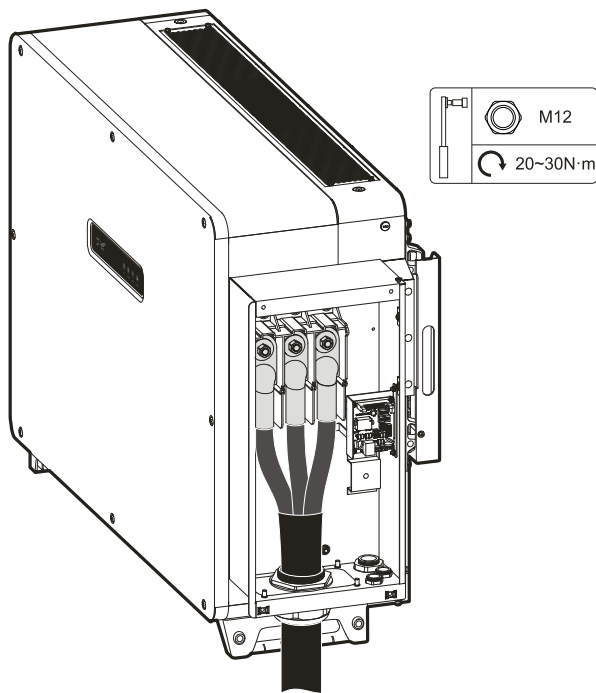

Figure3-32 Connect the AC output cable

NOTE

The torque used to tighten the external forced cable fixing head of AC wiring is about 15~19N·m.

**CAUTION**

In order to avoid excessive stress on the cable, the AC cable needs to enter the inverter vertically, and the external length of the straight section should be not less than 200mm, as shown in Figure3-33.

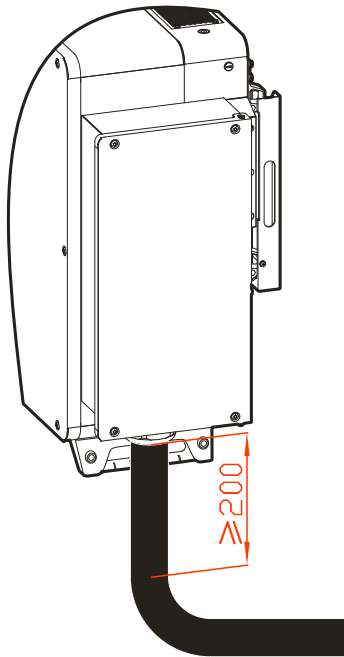

Figure3-33 AC cable entry requirements (unit: mm)

 **NOTE**

- When leaving the factory, outlet end of the cable seal ring is in a sealed status. Before connecting, puncture it by tool.
- Please connect the AC output wire according to the relevant requirements of different countries.

Step 3 Tighten the externally forced cable fixing head of the AC terminal clockwise, using a fireproof mud cable gap.

----End

3.6.5 Internal Grounding Connection

Loosen the external forced cable fixing head of the inner grounding terminal, lead the grounding wire go through the external forced cable fixing head, use a wire stripper to strip the grounding wire and crimp it to the grounding terminal, and then connect it to the inner grounding bar, as shown in Figure3-34.

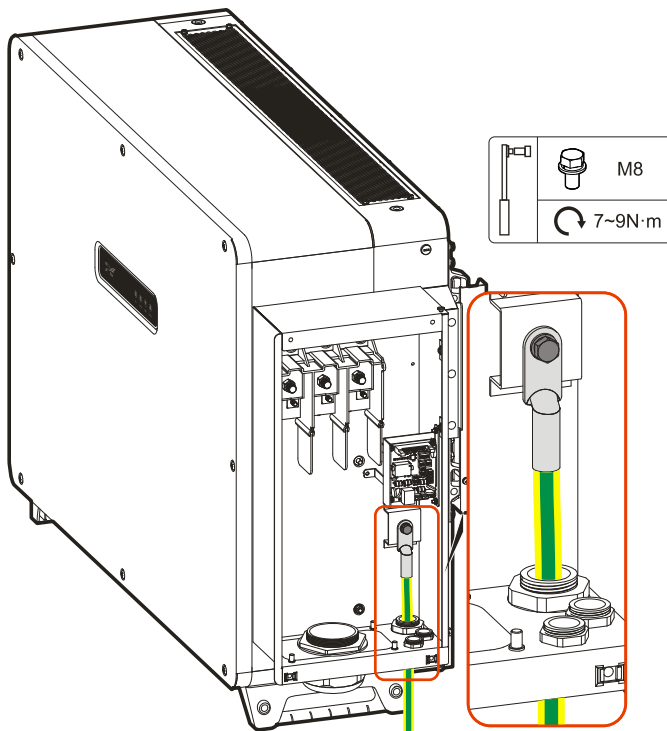

Figure3-34 Connect internal grounding cable

NOTE

The torque used to tighten the externally forced cable fixing head of the inner grounding wire is about 10~13N·m.

3.6.6 PV String Input Wiring



DANGER

Pay attention to safety before electrical connection, the PV string will produce dangerous voltage when exposed to sunlight.

**WARNING**

If the DC input wires are reverse connected by accident and the "DC SWITCH" have been set to the "ON", do not immediately operate the "DC SWITCH" and the positive and negative connectors, or, it may cause inverter damage. The resulted inverter damage is not covered by warranty. It needs to wait until night when the solar irradiance decreases and the PV string current drops below 0.5A, then place the corresponding "DC SWITCH" to "OFF" position, remove the positive and negative connectors and correct the polarity of the PV string.

**CAUTION**

- Before connecting the PV string to the inverter, ensure that the PV string is well insulated from ground.
 - When installing, use the DC terminals and PV connectors in the accessories, or, the inverter will be damaged. If they are lost or damaged by accident, please purchase the same type of PV connector. Inverter damage caused by the using incompatible PV connectors is not covered by the warranty.
 - Disconnect the DC switches before connecting the PV string.
 - Make sure that the positive and negative poles of the PV string and the inverter are correctly connected.
 - Ensure that the DC input voltage is less than 1500Vdc, and the maximum short-circuit current of the PV string is within the allowable range of the inverter.
 - It is strictly prohibited to connect the positive and negative poles of PV string to ground, or, it will cause damage to the inverter.
-

Use the PV connectors and terminals in the accessories for DC input wiring. There are two types of PV connectors: positive and negative connectors, which respectively use positive metal terminals and negative metal terminals. The specific steps are as follows.

Connect PV connectors

- Step 1 Use a wire stripper to strip the insulation layer of the positive and negative cables by 7mm, as shown in Figure3-35.



Figure3-35 Schematic diagram of stripping DC input wiring (Unit: mm)

NOTE

It is recommended to use red for positive cables and black for negative cables to avoid wiring errors. If other colors are used, please confirm the corresponding relationship when crimping each cable to the connector.

Step 2 Loosen the lock nuts of the positive and negative connectors, lead the positive and negative cables go through the corresponding lock nuts, and use a crimping tool to press the positive cable and negative cable to the positive and negative metal terminals respectively, as shown inFigure3-36.

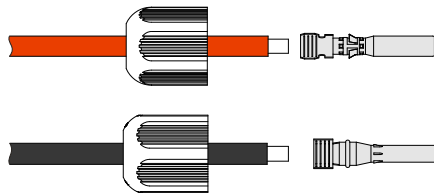

Figure3-36 Crimp metal terminals

Step 3 Insert the crimped positive and negative cables into the corresponding insulating shells until you hear a clicking sound, it means the connection is completed.

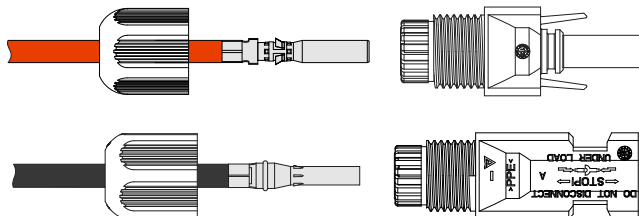

Figure3-37 Fixed metal terminal

Step 4 Screw and tighten the locking nuts of the positive and negative connectors to corresponding insulating shells, as shown in Figure3-38.

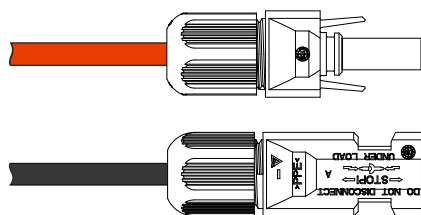

Figure3-38 Tighten the lock nut

---End

Wiring illustration for type-Y PV connector



CAUTION

When wiring by type-Y PV connector, the type of all connectors must match that of the inverter. If using the connector with different manufacturer or different type together, the contact resistance of the connector may exceed the allowable value, it will continue to heat and oxidize and easy to break down.

Wiring principle:

- For each MPPT, at most one set PV connector of type-Y can be connected.
- The PV+ of inverter side must be connected to the PV+ of PV string side, the PV- of inverter side must be connected to the PV- of PV string side. They cannot be connected mixed.

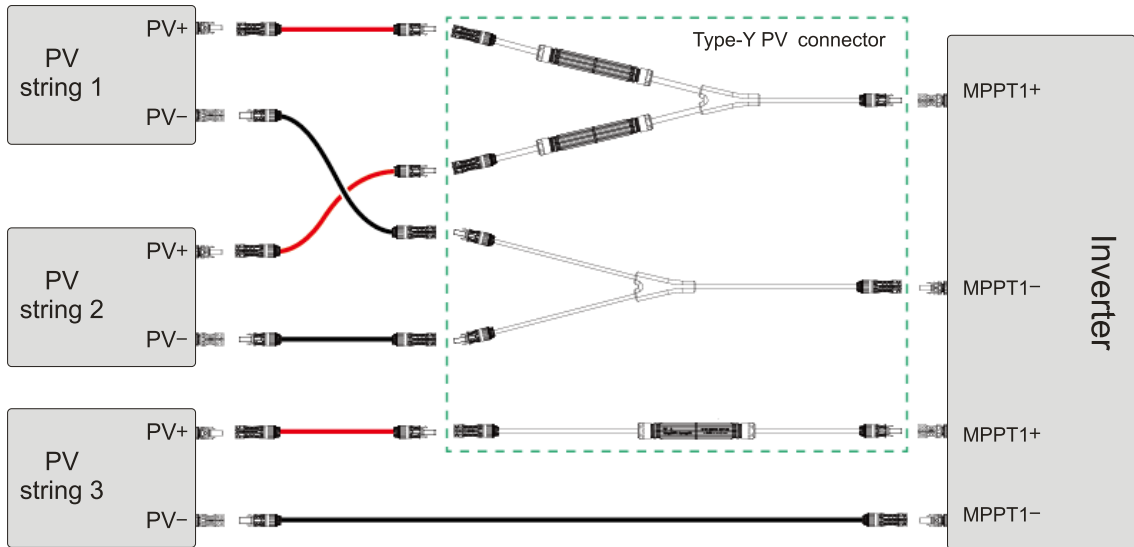

Figure3-39 Wiring diagram (connected from inverter side)

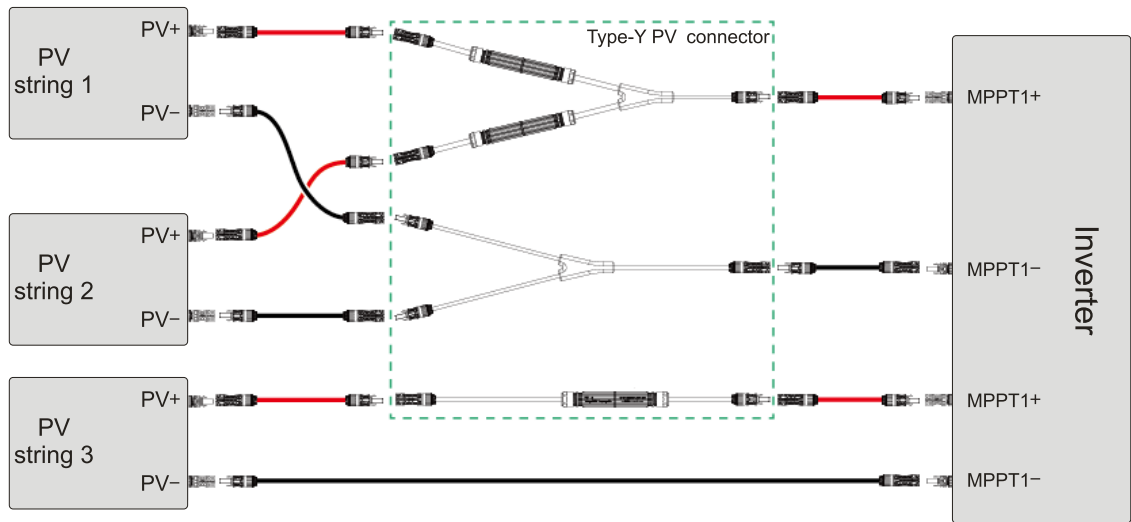

Figure3-40 Wiring diagram (connected from PV string)

Install PV connectors

Step 1 Confirm that all DC switches on the inverter (shown as ② in Figure3-41) are OFF.

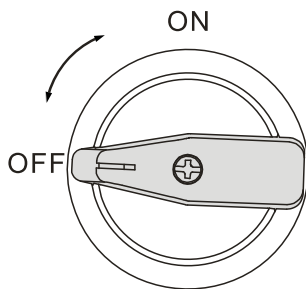

Figure3-41 Diagram of DC switch OFF status

Step 2 Check whether the polarity of the PV string is correct, and ensure that the open-circuit voltage in any case not exceeds the maximum input voltage of the inverter 1500V.

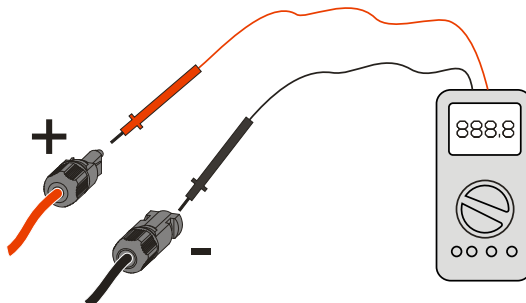

Figure3-42 Measuring open-circuit voltage

Step 3 Insert the positive and negative connectors into the MPPT "+" and "-" terminals on the bottom of the inverter respectively (as shown in Figure3-43). When you hear a click, it means the connection is completed.

NOTE

Each MPPT must have PV string connected.

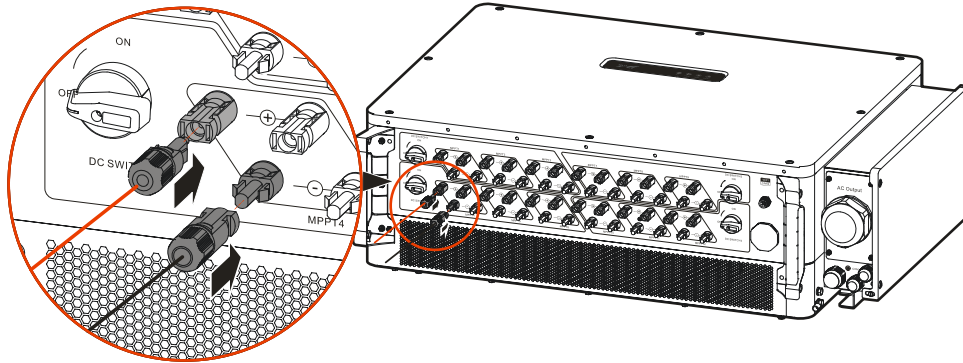

Figure3-43 Connect PV connectors



CAUTION

If any PV connector on the inverter is not connected to PV string, block it with original plug.

----End

3.6.7 WIFI/GPRS Communication Connection (Optional)

If WIFI/GPRS stick is configured, insert it into the WIFI/GPRS port to monitor, as shown in Figure3-44.

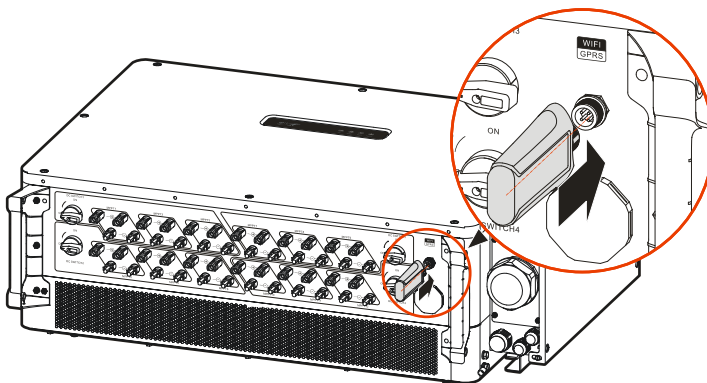

Figure3-44 WIFI/GPRS communication connection



CAUTION

When connecting, pay attention to the limiting position, and don't wrongly insert it. When tightening, do not use excessive force (torque: 1.5~2.0N•m), so as not to damage the interface.

NOTE

- The GPRS do not need to set.
- For the use of WIFI and GPRS, please scan the QR code on the WIFI/GPRS.

3.6.8 COM. Communication Connection

COM. communication includes Ethernet communication and RS485 communication.

Step 1 Loosen the external forced cable fixing head of "COM.", and then lead the communication cable go through the external forced cable fixing head.

Step 2 Connect the communication wire.

- Ethernet communication connection

Crimp the Ethernet communication wire according to Figure3-45, and then plug it into the Ethernet port on the communication board, as shown in Figure3-46. Connect the other end to the monitoring platform or router.

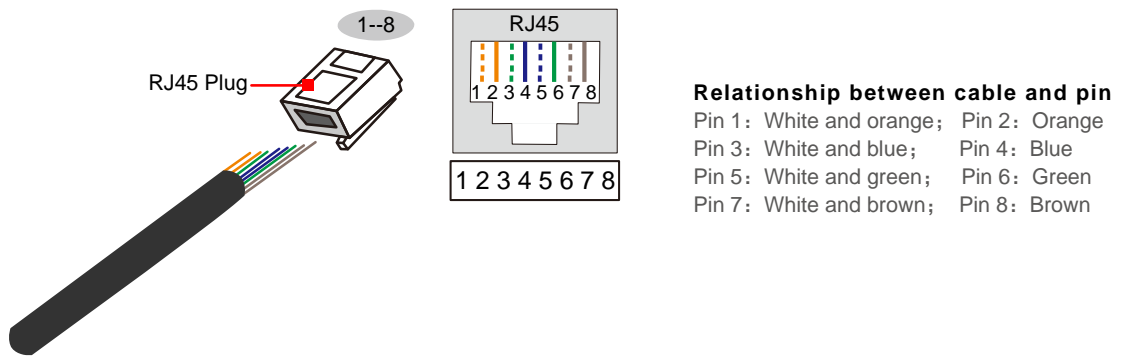

Figure3-45 Diagram of crimping of Ethernet communication wire

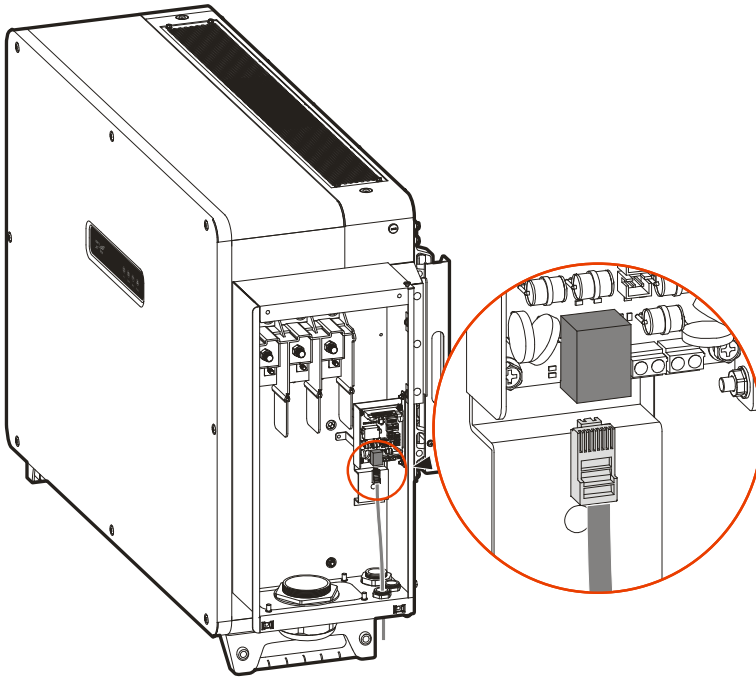

Figure3-46 Ethernet communication connection

- RS485 communication connection

Connect the RS485 communication wires to the RS485 port on the communication board, as shown in Figure3-47, and connect the other end to the monitoring platform.

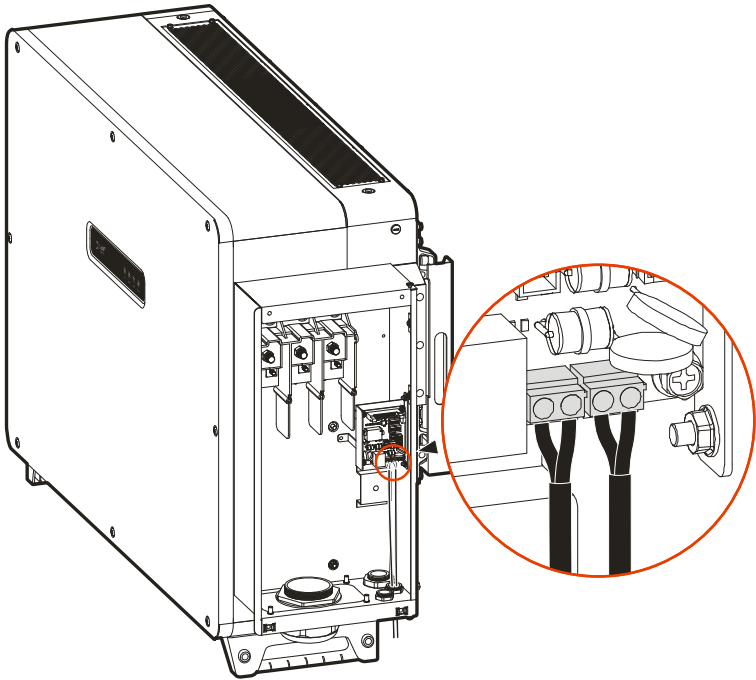

Figure3-47 RS485 connection



CAUTION

- When connecting, do not press the insulation layer of the communication cable into terminal, otherwise it may cause poor contact.
- The RS485 communication wire must be routed separately from the input and output wires to avoid interference with communication.



NOTE

The baud rate of the inverter needs to be set through Kehua monitoring software WiseEnergy (for details, please refer to the **About-User Manual** in WiseEnergy). The default baud rate is 9600. The communication address of the inverter is set in binary mode through the dial switch SW1 (position shown in Figure3-48) on the communication board, for example: when the dial switch SW1 is set to "000001 (from left to right, ON is 1, OFF is 0)", which means the communication address of the inverter is 1, and so on. If in doubt, please contact the manufacturer.

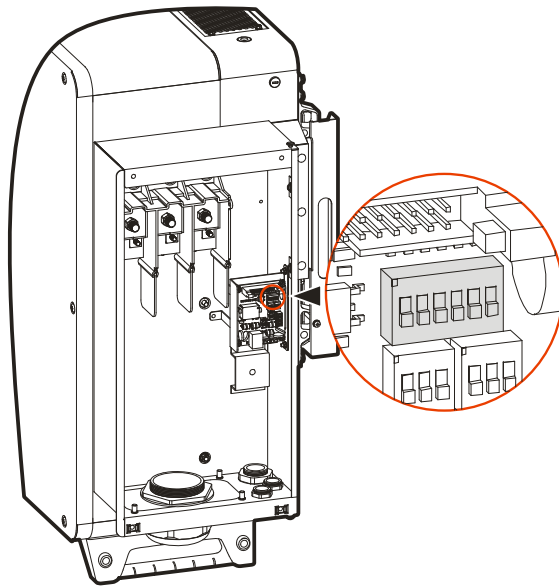

Figure3-48 Position of SW1



NOTE

When multiple inverters are communicating, the dial switches SW3 on the communication boards of first and last inverter on the communication link must be switched to the ON position.

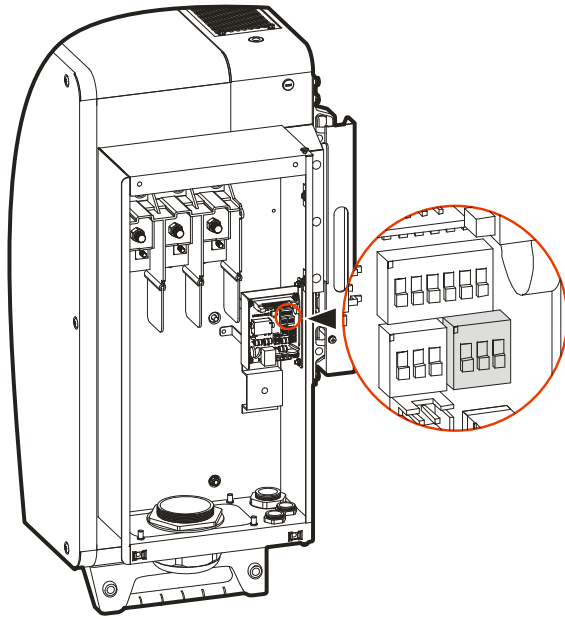

Figure3-49 Position of SW3

**CAUTION**

The communication address of the inverter must not conflict.

Step 3 After connecting, tighten the external forced cable fixing head, seal with fireproof mud and install the cover plate.

---End

3.7 Check the Installation

After installation, check the following items:

- Check if the connection of DC input, AC output and communication wire are right.
- Check if the inverter is installed firmly.
- Check if all the screws on the surface of the inverter are tightened.

4 Startup and Shutdown

This chapter mainly introduces how to start and shut down the inverter.

4.1 Check Before Startup

Before first startup, please check the following items first.

- Ensure that the inverter is properly installed and fastened.
- Ensure that the DC switches and external AC breakers are all disconnected.
- Ensure that the input polarity of PV string is correct.
- Ensure that all wires are fastened and the cable sheath with no damage.
- Ensure that the gap between connector and wires and unconnected connector has been sealed up and filled with fireproofing mud.
- Ensure that the grid voltage meets the AC voltage requirement of the inverter.
- Ensure that the input cables meet the current requirements of max. load.
- Ensure that the distance among AC terminals meet the requirements of safety standard.
- Ensure that the input voltage of each PV string in accordance with each other's.

4.2 Start Inverter



DANGER

Damaged device or device fault may cause electric shock or fire!

- Before operation, please check if the inverter is damaged or has other danger.
 - Check the external device or circuit connection and see if it is safe.
-

After ensure the inverter is normal, start the inverter according to following steps.

- Step 1 Switch on the DC switches on the inverter and the project site. When the PV string provides enough startup voltage, PV string indicator will be on.
- Step 2 Switch on the AC switch between inverter and grid, the fault indicator off.
- Step 3 When the DC and AC power are all normal, the inverter will prepare to start.
- Step 4 A moment later, the inverter will generate power normally. The grid indicator will be on.

----End

4.3 Shut Down Inverter



WARNING

When the inverter is in normal operating, it is strictly prohibited to disconnect the switches at DC and AC side under load to avoid the risk of arc damage to the switch. In severe cases, the inverter may be damaged.

- Step 1 Switch off the external AC switch between the inverter and grid.
- Step 2 Switch off the DC switches on the inverter and project site, after awhile, PV string indicator light off.

----End

5 Maintenance and Troubleshooting

This chapter mainly describes the maintenance and troubleshooting.

5.1 Maintenance



NOTE

If any maintenance service is needed, please contact the after-sale service centre of Kehua Company, otherwise, Kehua Company will not undertake the responsibility and guarantee for the loss caused by self-operation.



CAUTION

For human safety, before check and maintenance, disconnect the external AC switch, and then switch off the DC switches on the inverter. Wait for 30min, measure the inner DC bus voltage by multimeter and ensure the voltage below 10V, and then the maintenance can be done.

5.1.1 Maintenance Details and Period

To ensure the inverter works in best condition, we suggest maintaining the inverter regularly.

Table5-1 Check list

Item	Check method	Maintenance period
Cleanness of system	Check if there is dust or sundries on air outlet holes or heat sink. Clean the air outlet holes and heat sink if necessary.	Every half or one year (it is decided by the dust of the environment)
Electric connection	Check if the wiring is loose or dropping. Check if there is damage on the cables, especially the surface touching with metal, if damaged, please	Every half or one year

Item	Check method	Maintenance period
	maintain it in time.	
Wire Inlet hole	Check if the wire inlet holes are sealed up completely, if not, seal them with fireproof mud.	Every year
Fan	Check if there is abnormal noise on fan when running. Check if the blade of fan has crack. If necessary, replace the fan (refer to 5.1.2 Maintenance Guide)	Every year (if the operating environment with lots of sand and wind, short the maintenance period)
LED indicator	If the surface of the LED indicator is too dirty to read, you can clean it with a damp cloth.	In necessary

**CAUTION**

Do not clean the inverter with any solvent, abrasive material or corrosive material.

**HIGH TEMPERATURE**

During running, please don't touch the surface to avoid scald. Shut down inverter and wait until it cooling down, then do the maintenance.

**NOTE**

When the power generation value displayed on the monitoring platform is inconsistent with the external measurement device, user can correct the power generation value of the monitoring platform according to the Kehua communication protocol.

The correction formula is: Total power generation compensation value = Measurement value of measurement instrument - Monitoring platform displayed total power generation value.

5.1.2 Maintenance Guide

Clean wind inlet & outlet holes

During operating, the inverter will generate large heat, so, the inverter designs the cooling way of forced wind-cooling. To ensure good ventilation, it is necessary to check the wind inlet & outlet holes

and keep them unblocked. If necessary, a soft brush can be used to clean the wind inlet & outlet holes.

Fan maintenance



WARNING

Before maintenance, shut down the inverter and disconnect all power input.

Wait for 30min at least, after the inner capacitor discharge completely, the maintenance can be done.

The maintenance and replacement for fan only can be done by professional electric person.

The inner fans are used for cooling and heat dissipation while operating. If the fans cannot work normally, it will influence the inverter efficiency or cause derating running. So, keep the fan clean and replace the damaged fan in time. The fan's cleanness and replacement procedure as follows.

- Step 1 Shut down the inverter (see **4.3 Shut Down Inverter**).
- Step 2 Loosen the screws of fan module, as shown in Figure5-1.

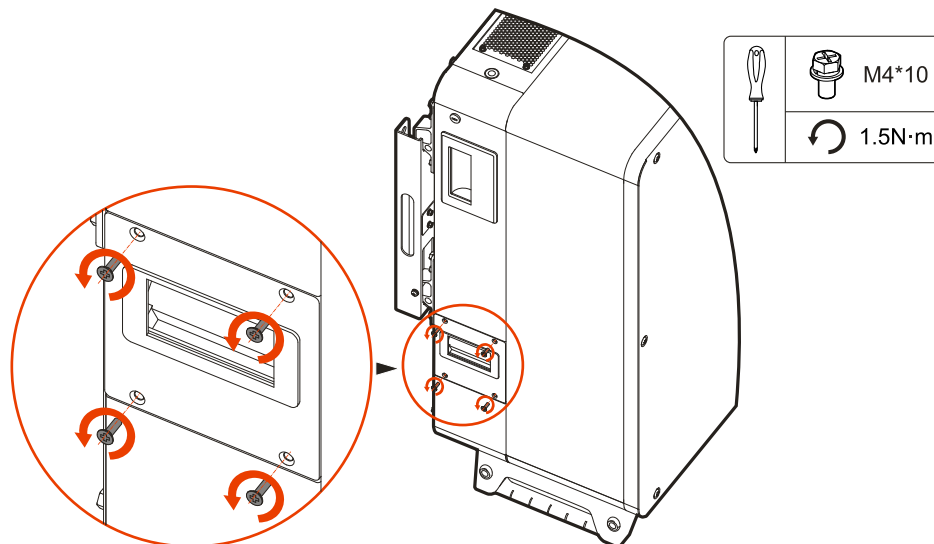

Figure5-1 Loosen the screws of fan cover

- Step 3 Pull out the fan module gently and loosen the connector of fan.

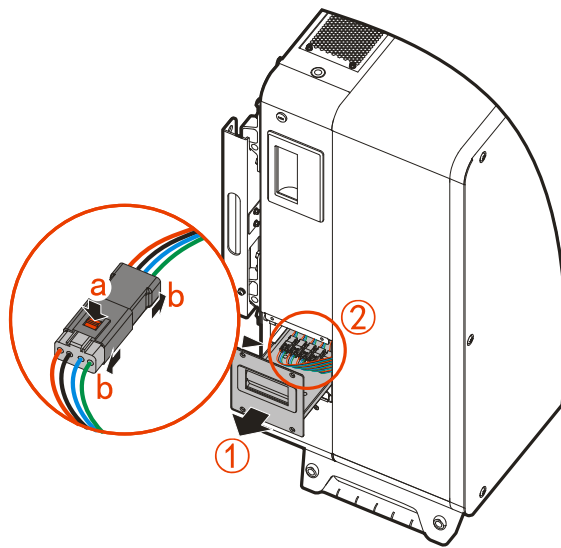

Figure5-2 loosen the wiring of fan module

Step 4 Pull out the fan module, clean the fan by brush or cleaner or replace damaged fan.

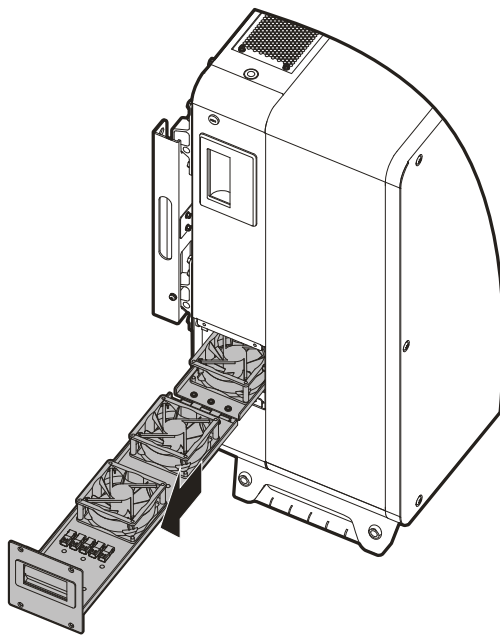

Figure5-3 Pull out fan module

Step 5 Install the fan module in reversed order and lock the screws, restart the inverter.

----End

5.2 Troubleshooting

The inverter is designed on the basis of the grid-tied operation standards and meets the requirements of safety and EMC. Before provided to client, the inverter has been experienced for several rigorous tests to ensure reliable and optimizing operation.

If some faults occur, the touch screen will show the corresponding alarm information. Under the circumstances, the inverter may stop power generation. The fault situation is as shown in Table5-2.

Table5-2 Troubleshooting list

NO.	Fault information	Solution
1	Grid voltage abnormal	Check whether the safety regulations of the inverter meet the requirements of the local grid connection and check the voltage of the local power grid. If the above is normal, please contact your local agency or service center.
2	Grid frequency abnormal	Check whether the safety regulations of the inverter meet the requirements of the local grid connection and check the frequency of the local power grid. If the above is normal, please contact your local agency or service center.
3	Output over-current	If the fault persists, please contact your local agency or service center.
4	Output current DC component abnormal	If the fault persists, please contact your local agency or service center.
5	Leakage current abnormal	Check the insulation resistance of the positive and negative poles of the battery board to the ground; check whether the environment around the inverter is wet; check the grounding of the inverter. If the above is normal, please contact your local agency or service center.
6	Relay fault	If the fault persists, please contact your local agency or service center.
7	Radiator over-temperature	Check whether the radiator of the inverter is blocked, and check whether the ambient temperature of the inverter is too high or too low. If the above is normal and the fault still exists, please contact your local agency or service center

NO.	Fault information	Solution
8	Insulation impedance abnormal	Check the insulation resistance of the positive and negative poles of the battery board to the ground; check whether the environment around the inverter is wet; check whether the grounding point inside the inverter is loose. If the above is normal, please contact your local agency or service center
9	Fan abnormal	If the fault persists, please contact your local agency or service center
10	Inner over-temperature	Check whether the radiator of the inverter is blocked, and check whether the ambient temperature of the inverter is too high or too low. If the above is normal and the fault still exists, please contact your local agency or service center.
11	MPPT over-voltage x	Check the system battery board configuration, if the above is normal, please contact your local agency or service center
12	MPPT over-current x	If the fault persists, please contact your local agency or service center
13	Branch over-current x	Check the system battery board configuration, if the above is normal, please contact your local agency or service center
14	Branch x reverse connected	Check whether the branch x is connected in reverse, if the above is normal, please contact your local agency or service center
15	Inner abnormal	If the fault persists, please contact your local agency or service center

**CAUTION**

If the inverter has an alarm mentioned in Table5-2, please shut down inverter (refer to **4.3 Shut Down Inverter**), 5 minutes later, restart the inverter (refer to **4.2 Start Inverter**). If the alarm status is not removed, please contact our local agency or service center. Before contacting us, please prepare the following information.

1. Inverter S/N.
 2. Distributor/ dealer of the inverter (if has).
 3. The date of grid-tied power generation.
 4. Problem description.
 5. Your detail contact information.
-

6 Stop Running, Dismantle, Discard Inverter

This chapter introduces the dispose way for stop running, dismantling, discarding the inverter.

6.1 Stop Running

Normally, the inverter don't need to be shut down, but when maintenance, it is necessary to shut down the inverter.



CAUTION

Please disconnect the AC and DC connection of inverter according to following procedure successively, or, it may cause human injure or device damage.

- Step 1 Disconnect the external AC breaker, and set warning marks at disconnected site to avoid improperly switching and even cause accident.
- Step 2 Switch OFF the DC switches on the inverter.
- Step 3 Wait for 30min at least, ensure that the inner capacitor discharge completely.
- Step 4 Loosen the locked part of PV string connector by MC4 wrench, take down the PV string connectors.
- Step 5 Dismantle the AC wiring box, measure the wires and ensure that there is no electricity in the AC wires, and then dismantle the AC wires and communication wires.
- Step 6 Install waterproof plug MC4 and AC waterproof box.

----End

6.2 Dismantle the Inverter



WARNING

After the connection among inverter and grid and PV string is completely disconnected and wait for 30min at least, ensure that the inner capacitor discharge completely, and then the inverter can be dismantled.

- Step 1 Disconnect all connection successively in reversed procedure of **3.6 Electrical Connection**.
- Step 2 Dismantle the inverter in reversed procedure of **3.5 Inverter Installation**.
- Step 3 If the inverter will be installed and used in the future, please dismantle the installation holder on the wall or bracket, then package and store the inverter properly. (see **7.1 Package** and **7.3 Storage**).

---End

6.3 Discard the Inverter

For the inverter that certain not to be used, user needs to discard the inverter according to related provision.



CAUTION

The battery, module and other components inside the inverter may pollute the environment, please do corresponding dispose on the basis of related provision.

7 Package, Transportation, Storage

This chapter mainly describes the package, transportation and storage.

7.1 Package

The package of product is carton. When packing, pay attention to the placing direction requirements. One side of carton, it should print warning icons, including keep dry, handle with care, up, stacking layer limit, etc. The other side of carton, it should print the device model, etc. Print the logo of Kehua company and device name on the front of carton.

7.2 Transportation

Pay attention to the warnings on the carton. Don't impact severely when transportation. In case of damaging device, it should follow the placing direction that shows on the carton. Don't carry device with the objects that inflammable, explosive, or corrosive. Don't put device in the open-air warehouse when transshipment. Leaching and mechanical damage by rain, snow or liquid objects is prohibited.

7.3 Storage

When storing device, it should follow the placing direction that shows on the carton. The gap is 20cm between the carton and ground and the clearance is at least 50cm from carton to wall, heat source, cold source, windows or air inlet.

The storage environment temperature is $-40^{\circ}\text{C} \sim 70^{\circ}\text{C}$. If storing or transporting device beyond the working temperature, before startup, set it alone and wait for the temperature reaches to the range of the working temperature and keep the status more than four hours. In warehouse, It's prohibited that there has poisonous gas, objects that inflammable and explosive, corrosive chemical objects. Besides, it shouldn't have too strong mechanical shaking, impact and strong magnetic field. Under the storage conditions above, the storage period is six months. If it is beyond six months, it has to recheck.

Do not store the inverter in the open air. If it will be stored for long time, please check the tightness of the inverter and see if there is any abnormal inside the inverter.

A Technical Specifications

A.1 SPI175K-B-H

Items	Min.	Typical	Max.	Illustration
Max. PV input voltage (Vd.c.)	500	-	1500	-
MPPT working voltage with full load (Vd.c.)	860	-	1300	-
PV connected/ MPPT tracking	18/9			
DC current of each route (Ad.c.)	0	9	15	-
Max. input current (Ad.c.)	30*9			
PV short-circuit current (Ad.c.)	50*9			
PV input power (kW)	0	178	196	-
Startup voltage (Vd.c.)	-	550	-	
Grid features				
Output power (kVA)	-	175	193	-
Rated grid voltage (Va.c.)	800 (3P3W)			
Grid voltage range (Va.c.)	720	800	880	Settable (If it is necessary to set the parameter, please contact the manufacturer.)
Frequency range (Hz)	48	50	50.5	Settable (If it is necessary to set the parameter, please contact the manufacturer.)

Items	Min.	Typical	Max.	Illustration
Max. inverter backfeed current to the array (Ad.c.)	0			
Max. output over-current protection (Aa.c.)	250			
Maximum output fault current (Aa.c.)	591			
Current (inrush) (Aa.c.)	6.97			
Grid-tied inverting efficiency	-	-	99.0%	-
Grid-tied China efficiency	-	-	98.5%	-
Grid-tied current harmonic	-	-	3%	Under full-load
Power factor range	0.8 (ahead)	1	0.8 (lag)	-
Current DC component (mA)	<631			-
Output current (Aa.c.)	-	-	139.3	-
Protection grade(IP)	IP66			-
Isolation type	No isolation			With no transformer, the input cannot be connected with ground, or the grounding output must be with isolation transformer.
Heat dissipation way	Smart wind-cooling			-
Noise	<75 ± 2dB(A)@1m			Do not install in a noise-sensitive environment
Display way	LED indicator			-
Communication port	RS485/ Ethernet(optional)/ WIFI(optional)/ GPRS(optional)/ PLC(optional)			

Items	Min.	Typical	Max.	Illustration
Operation temperature (°C)	-35	25	60	-
Storage temperature (°C)	-40	25	70	-
Relative humidity	0%	-	100%	-
Atmosphere (kPa)	70	106	-	-
Altitude (m)	0	-	4000	When the altitude exceeds 3000m, it is necessary to decrease rated power to use.
Over-voltage category	II (DC)/III(AC)			
Pollution degree	III			

A.2 SPI200K-B-H

Items	Min.	Typical	Max.	Illustration
Max. PV input voltage (Vd.c.)	500	-	1500	-
MPPT working voltage with full load (Vd.c.)	860	-	1300	-
PV connected/ MPPT tracking	24/12			
DC current of each route (Aa.c.)	0	9	15	-
Max. input current (Ad.c.)	30*12			
PV short-circuit current (Ad.c.)	50*12			
PV input power(kW)	0	203	223	-
Startup voltage (Vd.c.)	-	550	-	-
Grid features				
Output power (kVA)	-	200	220	-

Items	Min.	Typical	Max.	Illustration
Rated grid voltage (V.a.c.)	800 (3P3W)			
Grid voltage range (V.a.c.)	720	800	880	Settable (If it is necessary to set the parameter, please contact the manufacturer.)
Frequency range (Hz)	48	50	50.5	Settable (If it is necessary to set the parameter, please contact the manufacturer.)
Max. inverter backfeed current to the array (A.d.c.)	0			
Max. output over-current protection (A.a.c.)	250			
Max. output fault current (A.a.c.)	674			
Current (inrush) (A.a.c.)	7.94			
Grid-tied inverting efficiency	-	-	99.0%	-
Grid-tied China efficiency	-	-	98.5%	-
Grid-tied current harmonic	-	-	3%	Under full-load
Power factor range	0.8 (ahead)	1	0.8 (lag)	-
Current DC component	<721mA			-
Output current (A.a.c.)	-	-	158.8	-
Protection grade (IP)	IP66			-
Isolation type	No isolation			With no transformer, the input cannot be connected with ground, or the grounding output must be with isolation transformer.
Heat dissipation way	Smart wind-cooling			-

Items	Min.	Typical	Max.	Illustration
Noise	$75 \pm 2\text{dBA}@1\text{m}$			Do not install in a noise-sensitive environment
Display way	LED indicator			-
Communication port	RS485/ Ethernet(optional)/ WIFI(optional)/ GPRS(optional)/ PLC(optional)			
Operation temperature (°C)	-35	25	60	-
Storage temperature (°C)	-40	25	70	-
Relative humidity	0%	-	100%	-
Atmosphere (kPa)	70	106	-	-
Altitude (m)	0	-	4000	When the altitude exceeds 3000m, it is necessary to decrease rated power to use.
Over-voltage category	II (DC)/III(AC)			
Pollution degree	III			

A.3 SPI225K-B-H

Items	Min.	Typical	Max.	Illustration
Max. PV input voltage (Vd.c.)	500	-	1500	-
MPPT working voltage with full load (Vd.c.)	860	-	1300	-
PV connected/ MPPT tracking	24/12			
DC current of each route (Ad.c.)	0	9	15	-
Max. input current (Ad.c.)	30*12			
PV short-circuit current (Ad.c.)	50*12			

Items	Min.	Typical	Max.	Illustration
PV input power (kW)	0	228	250.5	-
Startup voltage (Vd.c.)	-	550	-	
Grid features				
Output power (kVA)	-	225	247.5	-
Rated grid voltage (Va.c.)	800(3P3W)			
Grid voltage range (Va.c.)	720	800	880	Settable (If it is necessary to set the parameter, please contact the manufacturer.)
Frequency range(Hz)	48	50	50.5	Settable (If it is necessary to set the parameter, please contact the manufacturer.)
Max. inverter backfeed current to the array (Ad.c.)	0			
Max. output over-current protection (Aa.c.)	250			
Max. output fault current (Aa.c.)	758			
Current (inrush) (Aa.c.)	8.93			
Grid-tied inverting efficiency	-	-	99.0%	-
Grid-tied China efficiency	-	-	98.5%	-
Grid-tied current harmonic	-	-	3%	Under full-load
Power factor range	0.8 (ahead)	1	0.8 (lag)	-
Current DC component (mA)	<812			-
Output current (Aa.c.)	-	-	178.6	-

Items	Min.	Typical	Max.	Illustration
Protection grade (IP)	IP66			-
Isolation type	No isolation			With no transformer, the input cannot be connected with ground, or the grounding output must be with isolation transformer.
Heat dissipation way	Smart wind-cooling			-
Noise	<75±2dBA@1m			Do not install in a noise-sensitive environment
Display way	LED indicator			-
Communication port	RS485/ Ethernet(optional)/ WIFI(optional)/ GPRS(optional)/ PLC(optional)			
Operation temperature (°C)	-35	25	60	-
Storage temperature (°C)	-40	25	70	-
Relative humidity	0%	-	100%	-
Atmosphere (kPa)	70	106	-	-
Altitude (m)	0	-	4000	When the altitude exceeds 3000m, it is necessary to decrease rated power to use.
Over-voltage category	II (DC)/III(AC)			
Pollution degree	III			

A.4 SPI250K-B-H

Items	Min.	Typical	Max.	Illustration
MPPT input voltage (Vd.c.)	500	-	1500	-
MPPT working voltage with full load (Vd.c.)	860	-	1300	-

Items	Min.	Typical	Max.	Illustration
PV connected/ MPPT tracking	24/12			
DC current of each route (Ad.c.)	0	9	15	-
Max. input current (Ad.c.)	30*12			
PV short-circuit current (Ad.c.)	50*12			
PV input power(kW)	0	253	253	-
Startup voltage(Vd.c.)	-	550	-	
Grid features				
Output power (kW)	-	250	250	-
Rated grid voltage (Va.c.)	800V(3P3W)			
Grid voltage range (Va.c.)	720	800	880	Settable (If it is necessary to set the parameter, please contact the manufacturer.)
Frequency range(Hz)	48	50	50.5	Settable (If it is necessary to set the parameter, please contact the manufacturer.)
Max. inverter backfeed current to the array (Ad.c.)	0			
Max. output over-current protection (Aa.c.)	250			
Max. output fault current (Aa.c.)	780			
Current (inrush) (Aa.c.)	9.02			
Grid-tied inverting efficiency	-	-	99.0%	-
Grid-tied China efficiency	-	-	98.5%	-

Items	Min.	Typical	Max.	Illustration
Grid-tied current harmonic	-	-	3%	Under full-load
Power factor range	0.8 (ahead)	1	0.8 (lag)	-
Current DC component (mA)	<902			-
Output current (A.a.c.)	-	-	180.4	-
Protection grade (IP)	IP66			-
Isolation type	No isolation			With no transformer, the input cannot be connected with ground, or the grounding output must be with isolation transformer.
Heat dissipation way	Smart wind-cooling			-
Noise	<75 ± 2dBA@1m			-
Display way	LED indicator			-
Communication port	RS485/ Ethernet(optional)/ WIFI(optional)/ GPRS(optional)/ PLC(optional)			
Operation temperature (°C)	-35	25	60	-
Storage temperature (°C)	-40	25	70	-
Relative humidity	0%	-	100%	-
Atmosphere (kPa)	70	106	-	-
Altitude (m)	0	-	4000	When the altitude exceeds 3000m, it is necessary to decrease rated power to use.
Over-voltage category	II (DC)/III(AC)			
Pollution degree	III			

- Specifications are subject to change without prior notice.

B Quality Assurance

If the device fault in guarantee period, Kehua Hengsheng Co., Ltd. (hereinafter referred to as Kehua Company) will maintenance it free or replace new product.

Evidence

In guarantee period, user needs to show the purchase invoice of the product, and the trademark on the product must be clearly visible, or, Kehua Company have right to refuse the quality assurance.

Condition

- The replaced product must be returned to Kehua Company to dispose.
- Reasonable time should be reserved for Kehua Company to maintain the fault device.

Disclaimer

If any situation below occurs, Kehua Company have right to refuse the quality assurance.

- Beyond the free quality assurance period.
- Damaged by transportation.
- Improper installation, transformation or use.
- Used in the harsh environment that not allowed in the User Manual.
- Damaged by installation, maintenance, transformation or dismantling of other company server.
- Damaged by using component or software of non-standard or other company except Kehua Company.
- Beyond the installation and use range of related national standard.

- Damage caused by abnormal nature environment.

If the fault is caused by above situation and user requires to maintain it, we can provide paid maintenance service after our service organization decided.

To improve users' satisfaction continuously, our product and User Manual is upgrading. If the User Manual has difference with product, it may be caused by the version difference, please take the actual product as standard. If any question, please contact our company.

Software authorization

- It is prohibited to use part or whole data of the hardware or software of Kehua Company in any way for commercial purpose.
- It is prohibited to decompile, decrypt or destroy the original program design of the software developed by Kehua Company.

C Acronyms and Abbreviations

A

AC Alternating Current

D

DC Direct Current

L

LCD Liquid Crystal Display

LED Light-emitting Diode

M

MPPT Maximum Power Point Tracking

P

PE Protective Earthing

PV Photovoltaic

R

RS485 Recommend Standard485



KEHUA DATA CO., LTD.

ADD: No. 457, Malong Road, Torch High-Tech Industrial
Zone, Xiamen, Fujian, China (361000)

TEL: 0592-5160516 (8 lines)

FAX: 0592-5162166

[Http://www.kehua.com](http://www.kehua.com)



Technical Support

4402-03202 006